

TECHNICAL MANUAL

**OPERATOR'S, UNIT,
AND DIRECT SUPPORT
MAINTENANCE MANUAL
FOR**

**SHELTER, ELECTRICAL
EQUIPMENT**

S-250/G (UNSHIELDED)

(NSN 5411-00-999-4935)

S-250/G (SHIELDED)

(NSN 5411-00-489-6076)

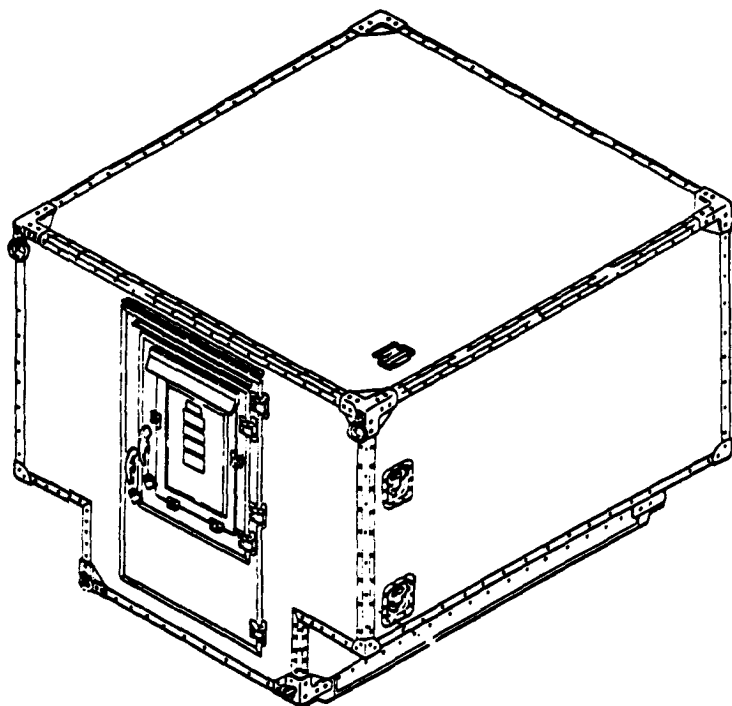

INTRODUCTION 1-1

OPERATING INSTRUCTIONS 2-1

**UNIT MAINTENANCE
INSTRUCTIONS 3-1**

**DIRECT SUPPORT
MAINTENANCE INSTRUCTIONS 4-1**

REFERENCES A-1

**MAINTENANCE
ALLOCATION CHART B-1**

**COMPONENTS OF END ITEM
AND BASIC ISSUE ITEMS LISTS C-1**

**EXPENDABLE/DURABLE
SUPPLIES AND MATERIALS LIST D-1**

This copy is a reprint which includes current pages from Change 1.

This Manual Supersedes TM 10-5411-205-14 dated 9 January 1989.

APPROVED FOR PUBLIC RELEASE DISTRIBUTION IS UNLIMITED.

HEADQUARTERS, DEPARTMENT OF THE ARMY

5 May 1990

WARNING

Drilling creates metal chips which may enter eyes and cause serious injury. Eye protection is required.

WARNING

Adhesives and solvents are flammable and toxic. Keep away from heat and open flames. Use in a well-ventilated area. Avoid skin and eye contact and breathing of vapors. Use protective goggles and gloves. Use in accordance with manufacturer's instructions. For Artificial Respiration, refer to FM21-11.

WARNING

Gloves are to be worn when mixing and applying adhesive material due to possible skin irritation caused by adhesive coming into contact with the body skin surface. The Versamid material is extremely sensitive to moisture absorption. Therefore, make sure Versamid 140 container has lid firmly replaced after material has been removed from shipping or storage container.

WARNING

All personnel must remain clear of truck while shelter is being lowered into place.

CHANGE
NO. 3

HEADQUARTERS, DEPARTMENT OF THE ARMY
WASHINGTON, DC, 31 AUGUST 2005

TECHNICAL MANUAL
OPERATOR'S, UNIT AND DIRECT SUPPORT MAINTENANCE MANUAL
FOR
SHELTER, ELECTRICAL EQUIPMENT

S-250/G UNSHIELDED NSN: 5411-00-999-4935
S-250/G SHIELDED NSN: 5411-00-489-6076

DISTRIBUTION STATEMENT A: Approved for public release; distribution is unlimited.

TM 10-5411-205-13, 5 May 1990, is updated as follows:

1. File this sheet in front of the manual for reference.
2. This change implements Army Maintenance Transformation and changes the Maintenance Allocation Chart (MAC) to support Field and Sustainment Maintenance.
3. New or updated change information is indicated by a vertical bar in the outer margin of the page.
4. Remove old pages and insert new pages as indicated below:

Remove Pages

B-1 through B-7/(B-8 blank)

Sample 2028

2028 – Front/Back

Insert Pages

A/(B blank)

B-1 through B-8

2028 Electronic Instructions/ Blank

Sample 2028 – Front/ Back

2028 – Front/Back

2028 – Front/Back

By Order of the Secretary of the Army:

PETER J. SCHOOMAKER
General, United States Army
Chief of Staff

Official:

SANDRA R. RILEY
*Administrative Assistant to the
Secretary of the Army*
0521011

Distribution: To be distributed in accordance with initial distribution number (IDN) 253646 requirements for TM 10-5411-205-13.

**CHANGE
NO. 2**

HEADQUARTERS
DEPARTMENT OF THE ARMY
WASHINGTON, D.C., 30 MAY 1995

Operator's, Unit, and Direct Support Maintenance Manual

for

**SHELTER, ELECTRICAL EQUIPMENT
S-250/G (Unshielded)(NSN 5411-00-999-4935)
S-250/G (Shielded)(NSN 5411-00-489-6076)**

DISTRIBUTION STATEMENT A Approved for public release; distribution is unlimited

TM 10-5411-205-13, 5 MAY 1990, is changed as follows:

1. Remove and insert pages as indicated below. New or changed text material is indicated by a vertical bar in the margin. An illustration change is indicated by a miniature pointing hand.

Remove pages

1-1 and 1-2

A-1/(A-2 Blank)

Insert pages

1-1 and 1-2

A-1/(A-2 Blank)

2. Retain this sheet in front of manual for reference purposes.

By Order of the Secretary of the Army:

Official:



JOEL B. HUDSON

*Acting Administrative Assistant to the
Secretary of the Army*

00328

GORDON R. SULLIVAN
*General, United States Army
Chief of Staff*

Distribution:

To be distributed in accordance with DA Form 12-25-E, block no. 3646, requirements for
TM 10-5411-205-13.

CHANGE

NO.1

HEADQUARTERS
DEPARTMENT OF THE ARMY
WASHINGTON, D.C., 4 MAY 1992

Operator's, Unit, and Direct Support Maintenance Manual

SHELTER, ELECTRICAL EQUIPMENT
S-250/G (Unshielded) (NSN 5411-00-999-4935)
S-250/G (Shielded) (NSN 5411-00-489-6076)

Approved for public release; distribution is unlimited

TM 10-5411-205-13, 5 May 1990, is changed as follows:

1. Remove and insert pages as indicated below. New or changed text material is indicated by a vertical bar in the margin. An illustration change is indicated by a miniature pointing hand.

Remove pages	Insert pages
1-1 through 1-4	1-1 through 1-4
3-1 through 3-4	3-1 through 3-4
3-15 and 3-16	3-15 and 3-16
3-41 and 3-42	3-41 and 3-42
3-45 and 3-46	3-45 and 3-46
3-69 and 3-70	3-69 and 3-70
B-7/(B-8 Blank)	B-7/(B-8 Blank)
C-3/(C-4 Blank)	C-3/(C-4 Blank)
D-1 through D-3/(D-4 Blank)	D-1 through D-3/(D-4 Blank)

2. Retain this sheet in front of manual for reference purposes.

By Order of the Secretary of the Army:

Official:

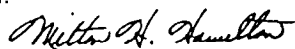

MILTON H. HAMILTON
*Administrative Assistant to the
Secretary of the Army*

01152

GORDON R. SULLIVAN
*General, United States Army
Chief of Staff*

DISTRIBUTION:

To be distributed in accordance with DA Form 12-25E, (qty rqr block no. 3646)

INSERT LATEST CHANGED PAGES. DESTROY SUPERSEDED PAGES.

LIST OF EFFECTIVE PAGES

NOTE: The portion of text affected by the changes is indicated by a vertical line in the outer margins of the page. Changes to illustrations are indicated by shaded or screened areas, or by miniature pointing hands. Zero in the "Change No. column indicates an original page.

Dates of issue for original and changed pages are:

Original .. 0 .. 5 May 1990
 Change .. 1 .. 4 May 1992
 Change .. 2 .. 30 May 1995
 Change .. 3 .. 31 August 2005

TOTAL NUMBER OF PAGES IN THIS PUBLICATION IS 148, CONSISTING OF THE FOLLOWING:

Page No.	Change No.	Page No.	Change No.
Title	0	3-43 - 3-69	0
a/(b blank)	0	3-70	1
i - iv	0	4-1 - 4-16	0
1-1	0	A-1/(A-2 blank)	2
1-2	2	B-1 - B-8	3
1-3 - 1-4	1	C-1 - C-2	0
1-5/(1-6 blank)	0	C-3/(C-4 blank)	1
2-1 - 2-4	0	D-1	0
3-1	0	D-2 - D-3/(D-4 blank)	1
3-2 - 3-3	1	Index 1 - Index 5/(Index 6 blank)	0
3-4	0	Back Cover	0
3-5 - 3-15	0		
3-16	1		
3-17 - 3-41	0		
3-42	1		

TECHNICAL MANUAL

No. 10-5411-205-13

HEADQUARTERS
DEPARTMENT OF THE ARMY
Washington, DC 5 May 1990

**Operator's, Unit, and Direct Support Maintenance Manual
for
SHELTER, ELECTRICAL EQUIPMENT
S-250/G (Unshielded) (NSN 5411-00-999-4935)
S-250/G (Shielded) (NSN 5411-00-489-6076)**

APPROVED FOR PUBLIC RELEASE DISTRIBUTION IS UNLIMITED.

REPORTING ERRORS AND RECOMMENDING IMPROVEMENTS

You can help improve this manual. If you find any mistakes or if you know of a way to improve the procedures, please let us know, Mail your letter, DA Form 2028 (Recommended Changes to Publications and Blank Forms), or DA Form 2028-2 located in the back of this manual direct to: US Army Troop Support coremand, ATTN: AMSTR-MCTS, 4300 Goodfellow Blvd., St. Louis, MO, 63120-1798. A reply will be furnished to you.

TABLE OF CONTENTS

	Page
CHAPTER 1	INTRODUCTION 1-1
Section I	General Information 1-1
Section II	Equipment Description and Data 1-2
CHAPTER 2	OPERATING INSTRUCTIONS 2-1
Section I	Operator Preventive Maintenance Checks and Services (PMCS) . . 2-1
Section II	Operation Under Usual Conditions 2-4
Section III	Operation Under Unusual Conditions 2-4
CHAPTER 3	UNIT MAINTENANCE INSTRUCTIONS 3-1
Section I	Lubrication 3-1
Section II	Repair Parts, Special Tools, TMDE, and Support Equipment . . . 3-1
Section III	Service Upon Receipt 3-1
Section IV	Troubleshooting 3-7
Section V	Maintenance Instructions. 3-11
Section VI	Preparation for Shipment and Storage 3-70
CHAPTER 4	DIRECT SUPPORT MAINTENANCE INSTRUCTIONS 4-1
Section I	Repair Parts, Special Tools, TMDE, and Support Equipment . . . 4-1
Section II	Troubleshooting 4-1
Section III	Maintenance Instructions 4-2

*This manual supersedes TM 10-5411-205-14 dated 9 January 1989.

TABLE OF CONTENTS (cont)

	Page
APPENDIX A REFERENCES	A-1
APPENDIX B MAINTENANCE ALLOCATION CHART	B-1
APPENDIX C COMPONENTS OF END ITEM AND BASIC ISSUE ITEMS LISTS	C-1
APPENDIX D EXPENDABLE/DURABLE SUPPLIES AND MATERIALS LIST	D-1
INDEX	Index 1

LIST OF ILLUSTRATIONS

Figure Number	Title	Page
1-1	Major Shelter Components	1-3
1-2	Shelter Marking	1-4
1-3	Instruction and Warning Plates	1-5
3-1	Lifting and Loading Shelter	3-3
3-2	Securing Shelter on Truck	3-4
3-3	Shelter Tiedown on M1028 Truck	3-6
3-4	Securing Shelter on M1037 Shelter Carrier	3-8
3-5	Rivet Types	3-12
3-6	Installing Blind Rivets	3-14
3-7	Removing Blind Rivets	3-15
3-8	Rivnuts (Threaded Inserts)	3-16
3-9	Installing Rivnuts	3-17
3-10	Removing Rivnuts	3-19
3-11	Repair of Turning Rivnut	3-20
3-12	Overall Shelter Assembly Inspection	3-24
3-13	Trough Replacement	3-25
3-14	Bail Handle Replacement	3-26
3-15	Recessed Step Pan Assembly Replacement	3-28
3-16	Drain Plug Replacement	3-29
3-17	Instruction Plate Replacement	3-30
3-18	Outer Door Assembly Replacement	3-32
3-19	Typical Locations for Door Gasket Testing	3-35
3-20	Weather Gasket and Seal Pressure Adjustment	3-36
3-21	Door Handle Assembly and Latching Mechanism Replacement	3-40
3-22	Keeper Assembly Replacement	3-42
3-23	Hinge Assembly Replacement	3-44
3-24	Door Hasp Replacement	3-45
3-25	Inner Door Assembly Replacement	3-47
3-26	Louver Assembly, Holder Assembly, and RFI/EMI Replacement	3-50
3-27	Directional Vane Assembly and Air Intake Filter Replacement	3-52
3-28	Louver Cover Assembly Latch Replacement	3-54
3-29	Shield (Rain Flap) Replacement	3-55
3-30	Louver Cover Assembly Replacement	3-57
3-31	Data Plate Replacement	3-58
3-32	Louver Cover Assembly Strike Replacement	3-59
3-33	Louver Cover Assembly Clip Replacement	3-60
3-34	Door Stay Assembly Repair and Replacement	3-62
3-35	Skid Assembly Replacement	3-64
3-36	Skid Assembly Repair	3-66
3-37	Towing Bracket Assembly Repair	3-67
3-38	Lifting Bracket Assembly Repair	3-68
3-39	Sling Assembly Repair	3-69
4-1	Skin Panel Delamination Repair	4-4
4-2	Shelter Wall Repair of Small Dent	4-8
4-3	Shelter Wall Repair of Large Dent	4-10
4-4	Shelter Wall Repair of Small Skin Puncture	4-12
4-5	Shelter Wall Repair of Large Skin Puncture or Cut	4-15

LIST OF TABLES

Table Number	Title	Page
2-1	Operator Preventive Maintenance Checks and Services	2-2
3-1	Troubleshooting	3-9
3-2	Blind Rivets	3-13
3-3	Rivnuts	3-17
3-4	Maximum Torque Requirement for Rivnut Screws	3-20
4-1	Troubleshooting	4-2

HOW TO USE THIS MANUAL

This manual was prepared to help keep your S-250/G Unshielded and S-250/G Shielded shelters in good operating condition. The front cover index is provided for quick reference to important information. There is also an alphabetical index at the back of the manual to locate specific items of information.

Warning pages are located at the front of this manual. You should read and completely understand all of the warnings before performing any maintenance on the equipment.

Paragraphs in this manual are numbered by chapter and order of appearance within a chapter. A subject index appears at the beginning of each chapter listing sections that are included in that chapter. A more specific subject index is located at the beginning of each section to help you find the exact paragraph you are looking for.

CHAPTER 1
INTRODUCTION

Subject	Section	Page
General Information	I	1-1
Equipment Description and Data	II	1-2

Section I. GENERAL INFORMATION

Subject	Para	Page
Scope	1-1	1-1
Maintenance Forms and Records	1-2	1-1
Reporting Equipment Improvement Recommendations	1-3	1-1
Destruction of Army Materiel to Prevent Enemy Use	1-4	1-1
Preparation for Shipment and Storage	1-5	1-1
Warranty Information	1-6	1-2
List of Abbreviations	1-7	1-2

1-1. Scope.

a. Type of Manual. This technical manual includes operator, unit and direct support maintenance procedures for the S-250/G Unshielded and S-250/G Shielded shelters. Additional maintenance data relevant to a specifically configured shelter can be found in the applicable end item technical manual.

b. Equipment Name and Model Number. This technical manual covers Electrical Equipment Shelter S-250/G Unshielded and S-250/G Shielded. The S-250/G Shielded shelter is equipped with radio frequency/electromagnetic interference shielding.

c. Purpose of Equipment. The S-250/G Unshielded and S-250/G Shielded are light-weight transportable shelters designed to house a wide variety of military systems and components.

1-2. Maintenance Forms and Records. Department of the Army forms and procedures used for equipment maintenance will be those prescribed by DA Pam 738-750, The Army Maintenance Management System (TAMMS).

1-3. Reporting Equipment Improvement Recommendations (EIR). If your shelter needs improvement, let us know. Send us an EIR. You, the user, are the only one who can tell us what you don't like about your equipment. Let us know why you don't like the design or performance. Put it on an SF 368 (Quality Deficiency Report). Mail it to: Commander, US Army Aviation and Troop Command, ATTN: AMSAT-I-MDO, 4300 Goodfellow Blvd., St. Louis, MO 63120-1798. We'll send you a reply.

1-4. Destruction of Army Materiel to Prevent Enemy Use. Destruction of Army equipment to prevent enemy use shall be in accordance with TM 750-244-3.

1-5. Preparation for Shipment and Storage. Refer to paragraph 3-37 for shipment and storage preparation data. Administrative storage requirements will be in accordance with the following:

a. Placement of equipment in administrative storage should be for short periods of time when a shortage of maintenance effort exists. Items should be in mission readiness within 24 hours or within the time factors as determined by the directing authority. During the storage period appropriate maintenance records will be kept.

b. Before placing equipment in administrative storage, current maintenance services and equipment serviceable criteria (ESC) evaluations should be completed, shortcomings and deficiencies should be corrected, and all modification work orders (MWO's) should be applied.

c. Storage Site Selection. Inside storage is preferred for items selected for administrative storage. If inside storage is not available, trucks, vans, conex containers and other containers may be used.

1-6. Warranty Information. The S-250/G Unshielded and S-250/G Shielded shelters are warranted by Gichner Shelter Systems or Ramim Engineering Works, Ltd. for 24 months. Warranty starts on the date found on DA Form 2408-9 (Equipment Control Record) in the logbook. Report all defects in material or workmanship to your supervisor who will take appropriate action. Refer to Warranty Technical Bulletin TB 10-5411-205-23 (Gichner) or TB 10-5411-205-23-1 (Ramim).

1-7. List of Abbreviations.

EMI	Electromagnetic Interference
R F I	Radio Frequency Interference
RTV	Room Temperature Vulcanizing
TMDE	Test, Measurement, and Diagnostic Equipment

Section II. EQUIPMENT DESCRIPTION AND DATA

Subject	Para	Page
Equipment Characteristics, Capabilities, and Features	1-8	1-2
Location and Description of Major Components	1-9	1-3
Equipment Data	1-10	1-3
Shelter Marking	1-11	1-4
Instruction and Warning Plates	1-12	1-4
Safety, Care, and Handling	1-13	1-5

1-8. Equipment Characteristics, Capabilities, and Features. The S-250/G Unshielded and S-250/G Shielded shelters are lightweight, relocatable shelters used to transport and house various types of equipment. The foam and beam shelter construction consists of aluminum face sheets enclosing a polyurethane foam composition core. The shelters are designed for outdoor use in all weather conditions. The shielded shelters are equipped with radio frequency/electromagnetic interference (RFI/EMI) shielding to protect the electronic equipment contained inside. The shield is a continuous metallic surface which includes the shelter panel outer face sheets and conductive materials which maintain continuity around joints, door openings, and other possible sources of radiation leak. Shielded shelters also have a RFI/EMI filter inside the inner (emergency) door. Shielded shelters can be identified by the metallic door gasket which mates with another conductive surface on the door jamb.

1-9. Location and Description of Major Components. (Figure 1-1)

ITEM	DESCRIPTION
1. Door assembly	Provides personnel access to interior of shelter.
2. Inner (emergency) door assembly	Provides emergency personnel exit and allows fresh air to enter shelter through an air vent with filter. The shielded shelters are provided with an RFI/EMI filter.
3. Lifting bracket assembly	Provides hookup point for sling assembly when lifting shelter and when securing shelter onto truck.
4. Towing bracket assembly	Provides hookup point for guide rope when guiding sling-lifted shelter into position and when securing shelter onto truck.
5. Recessed step pan assembly	Allows access to roof.
6. Skid assemblies	Permit a fully equipped shelter to be seated on rough terrain. They also provide forklifting access.

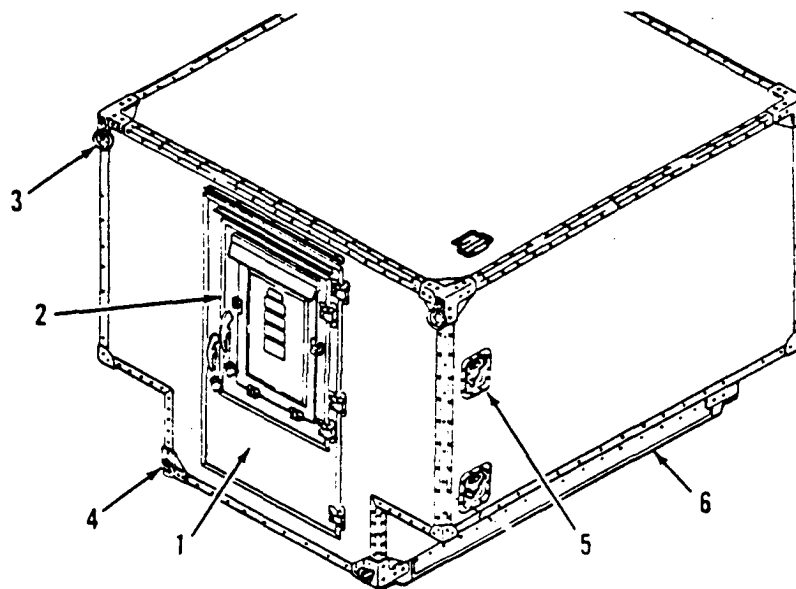

Figure 1-1. Major Shelter Components.

1-10. Equipment Data.

Height	70.125 in (178.11 cm)
Width	79.0625 in (200.82 cm)
Length	86.625 in (220.03 cm)
Gross weight	Shield 770 lb (349 kg) empty Unshielded 782 lb (355 kg) fully loaded
Cubage	273 ft ³ (6.93 m ³)
Load on skids	Empty 1.8 psi Fully loaded 6.2 psi

1-11. Shelter Marking. Shelter markings are shown in Figure 1-2. Lettering is stenciled or silkscreened in accordance with MIL-M-13231 GR II. The color used is black, MIL-C-46168; for camouflage painted shelters, markings shall be Green 383, MIL-C-46168; for black background, and black, MIL-C-46168; for green or brown backgrounds.

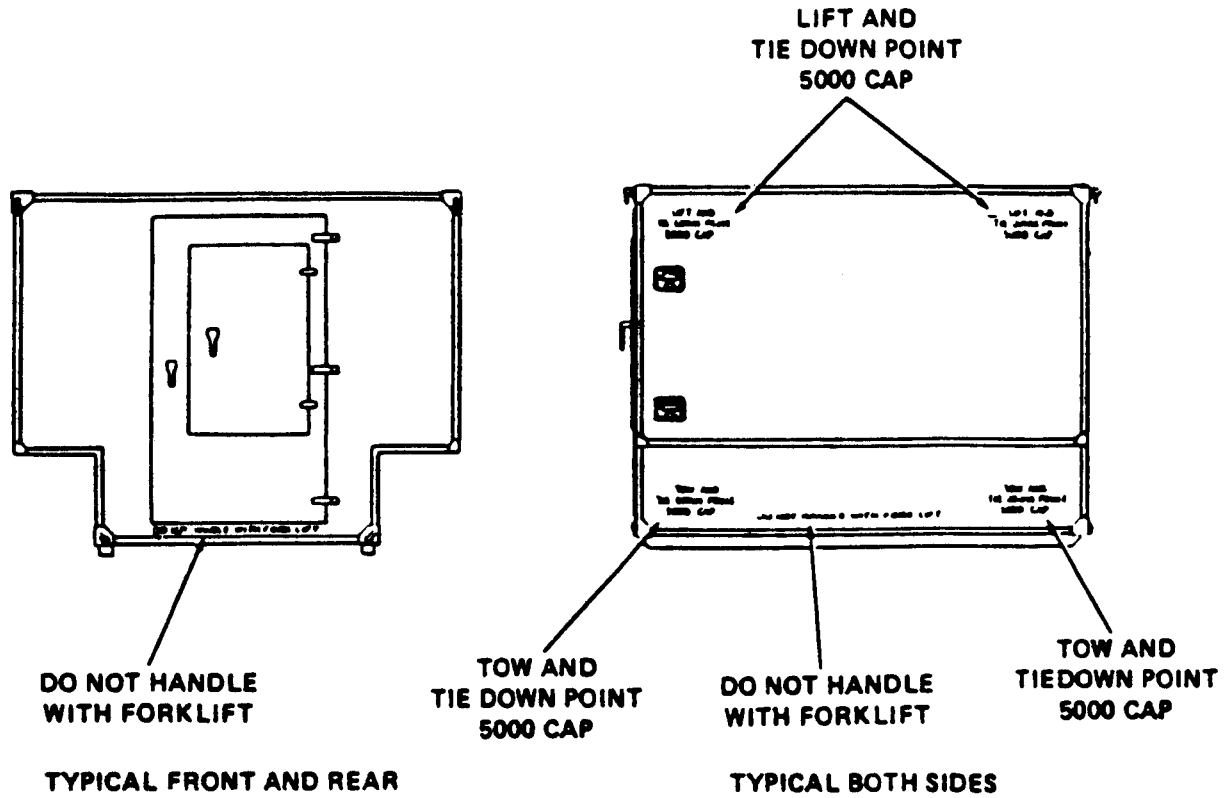

Figure 1-2. Shelter Marking.

1-12. Instruction and Warning Plates. (Figure 1-3)

ITEM	CONTENT
1. Warning Plate	WARNING Keep drain plug loose during air and rail transport
2. Instruction Plate	The surfaces of this shelter have been painted with CARC For touch-up Exterior - Use only lusterless green 383 polyurethane IAW MILC-46168 Interior - Use only epoxy polyamide IAW MILC-22750
3. Instruction Plate	For emergency exit remove wing screw and turn handle
4. Instruction Plate	Unlatch vent cover during airlift Keep vent cover open when shelter is occupied Remove drain plug during air and rail transport
5. Instruction Plate	Insert pin in holes to hold door open.

1-12. Instruction and Warning Plates (cent).

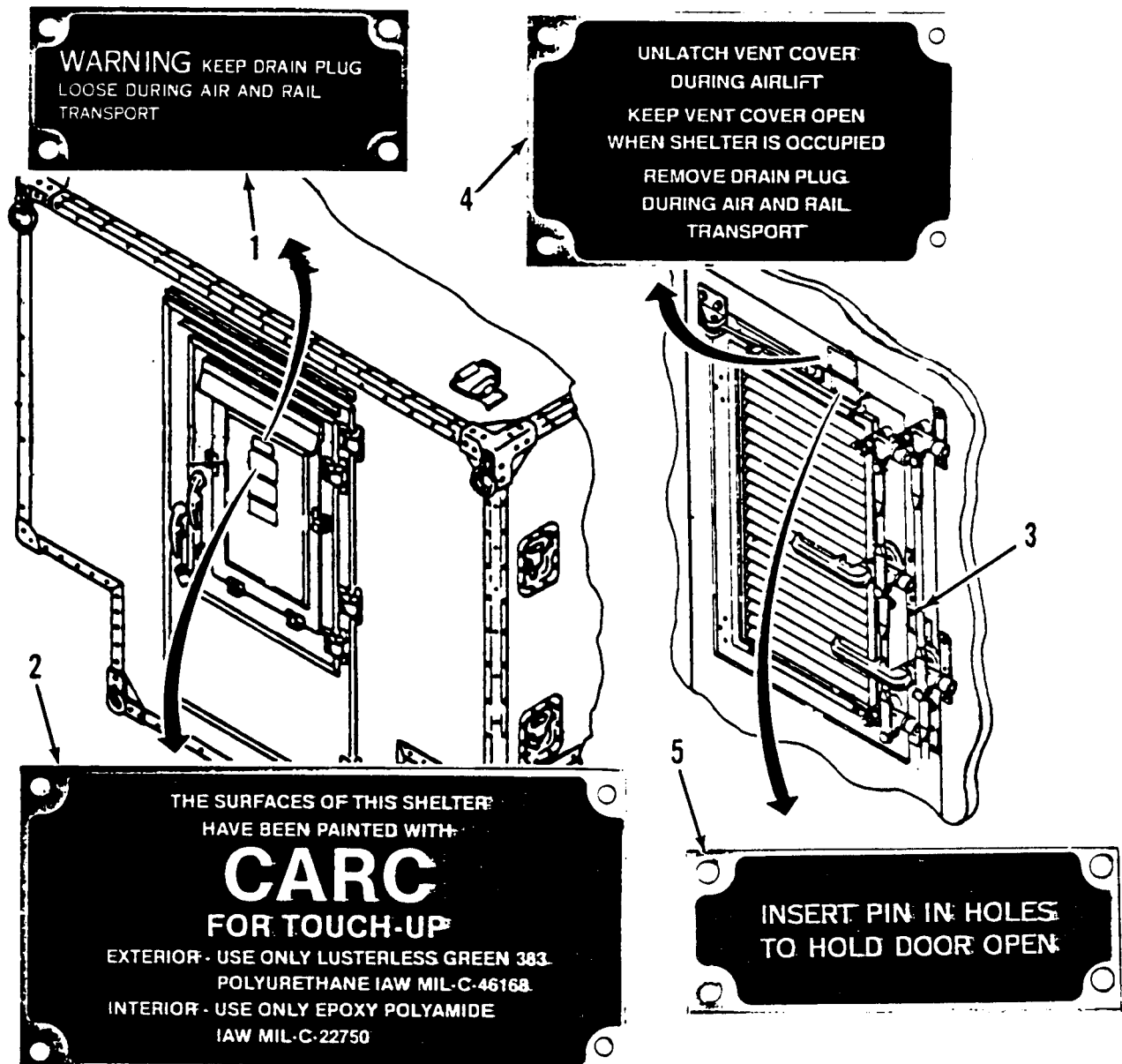

Figure 1-3. Instruction and Warning Plates.

1-13. **Safety, Care, and Handling.** Warnings, cautions, and notes designed to protect personnel and equipment when handling the shelter are located throughout this manual. Know the warnings before attempting to perform any maintenance on the shelter, and observe all warnings, cautions, and notes as you come upon them in the text.

CHAPTER 2

OPERATING INSTRUCTIONS

Subject	Section	Page
Operator Preventive Maintenance Checks and Services (PMCS)	I	2-1
Operation Under Usual Conditions.	II	2-4
Operation Under Unusual Conditions	III	2-4

Section I. OPERATOR PREVENTIVE MAINTENANCE CHECKS AND SERVICES (PMCS)

Subject	Para	Page
General	2-1	2-1
Purpose of PMCS Table	2-2	2-1
Explanation of Columns	2-3	2-1

2-1. General. To be sure the shelter is always ready for use, it must be inspected at specific intervals so defects can be located and corrected before they result in serious damage or failure.

a. Before You Operate. Always keep in mind the CAUTIONS and WARNINGS. Perform your before (B) PMCS.

b. While You Operate. Always keep in mind the CAUTIONS and WARNINGS. Perform **your** during (D) PMCS.

c. Afler You Operate. Be sure to perform your after (A) PMCS.

d. Weekly. Perform your weekly (W) PMCS.

e. Once Each Month. Perform your monthly (M) PMCS.

f. If Your Equipment Fails to Operate. If your equipment does not perform as required, notify higher level of maintenance. Report any malfunctions or failures on the proper DA Form 2404 or refer to DA Pam 738-750.

2-2. Purpose of PMCS Table. The Preventive Maintenance Checks and Services table lists the inspections required to keep the equipment in good operating condition.

2-3. Explanation of Columns.

a. Item Number. The item number is to be used as a source number for the TM number column on DA Form **2404**, Equipment Inspection and Maintenance Worksheet, when recording PMCS results.

b. Item to Be Inspected. This column list the components that require inspection.

c. Procedure. This column lists the faults to check for and procedures to follow.

2-3. Explanation of columns (cont).

d. Equipment is Not Ready/Available If. This column tells you when and why your equipment cannot be used.

NOTE

Perform your “weekly checks” in addition to the “before checks” if you are the assigned operator and have not operated the equipment since the last weekly check was performed, or if you are operating the equipment for the first time.

Table 2-1. Operator Preventive Maintenance Checks and Services.

NOTE

Within designated interval, these checks are to be performed in the order listed.

Item	Interval					Item to be Inspected	Procedures Check for and have repaired or adjusted as necessary	Item is Not Ready/ Available if
	B	D	A	W	M			
1	•			•		Door Handles	Make sure handles on inner and outer doors operate smoothly without binding or jamming.	Door cannot be opened or cannot be closed securely.
2	•			•		Louver Cover Assembly (Inner Door)	a. Make sure louver cover assembly can be held in the open position. b. Make sure weather gasket is in good condition. c. Make sure air filter, louvers and directional vanes are not blocked.	a. Louver cover assembly cannot be held open. c. Air filters, louvers or vanes are blocked.
3	•			•		Door Stay Assemblies	Make sure that each door stay assembly rod slides smoothly in channel and rotates easily in bracket. Check for loose or missing hardware or detent pin	
4	•			•		Door Assemblies, Inner and Outer	a. Make sure doors open and close smoothly without binding. Check hinges for loose or missing hardware. Lubricate hinges. b. Make sure rain flap above louver cover assembly is intact.	a. Door cannot be opened or cannot be closed securely.

Table 2-1. Operator Preventive Maintenance Checks and Services (cont).

Item	Interval					Item to be Inspected	Procedures Check for and have repaired or adjusted as necessary	Item is Not Ready/ Available if:
	B	D	A	W	M			
4	•				•	Door Assemblies, Inner and Outer (rent)	<p>c. Make sure troughs (drip moldings) above each door are mounted securely.</p> <p>d. Check door surfaces for punctures.</p> <p>e. Make sure weather gaskets are in good condition.</p>	
5	•				•	Lifting and Towing Bracket Assemblies	<p>a. Inspect for excessive wear.</p> <p>b. Inspect for rust, loose or missing hardware.</p> <p>c. Make sure rings and pins rotate freely.</p>	
6					•	Roof Access Steps	<p>a. Make sure steps stay in up or down position as required.</p> <p>b. Check for loose or missing hardware.</p>	
7					•	Roof Handle	Make sure handle is securely mounted to roof.	
8		•				Drain Plug	Make sure drain plug is in place.	Drain plug is missing (shielded shelters).
9		•			•	RFI/EMI Components	<p>a. Make sure metal door gaskets are complete and intact</p> <p>b. Make sure filter is in place and undamaged.</p>	<p>a. Gasket is not intact.</p> <p>b. Filter is not intact.</p>
10	•				•	Wall Floor, and Ceiling Panels	Inspect for punctures and delamination.	Punctures are present.
11	•				•	skids	Make sure skids are securely mounted to shelter and are undamaged.	

Section II. OPERATION UNDER USUAL CONDITIONS

Subject	Para	Page
Assembly and Preparation for Use	2-4	2-4
Initial Adjustments	2-5	2-4
Operating Procedure	2-6	2-4
Preparation for Movement	2-7	2-4

2-4. Assembly and Preparation for Use. There are no assembly or preparation procedures that must be performed before using the basic shelter. For all assembly and preparation procedures applicable to a specifically configured shelter, refer to the end item technical manual.

2-5. Initial Adjustments. The shelter itself requires no adjusting. However, the operator must make certain the shelter is positioned so the door can be fully opened and closed and that any external equipment required for operation of the shelter-contained equipment can be properly installed. Refer to the end item technical manual for any adjustment procedures applicable to the configured shelter.

2-6. Operating Procedure. There are no operating procedures applicable to the basic shelter. Refer to the end item technical manual for operating procedures applicable to a specifically configured shelter.

2-7. Preparation for Movement. Before moving the shelter, make sure the door is closed and padlocked. If the shelter is being moved by truck, make sure the shelter is properly tied down and blocked to prevent movement. Refer to paragraph 3-5 for instructions for securing the shelter on a truck. If the shelter must be loaded onto a truck for movement, refer to paragraph 3-5 for lifting and loading instructions. Refer to the end item technical manual for additional preparation instructions applicable to a specifically configured shelter.

Section III. OPERATION UNDER UNUSUAL CONDITIONS

Subject	Para	Page
Operation in Unusual Weather	2-8	2-4
Emergency Procedures.. . . .	2-9	2-4

2-8. Operation in Unusual Weather. The S-250/G Unshielded and S-250/G Shielded shelters are designed for use in all weather. However, shelters located at sites subject to salt air deterioration, or areas subject to wind-driven sand or coral dust shall be inspected by site personnel at least once every week to assure timely determination of maintenance and repair needs. Additional requirements for operation in unusual weather can be found in the end item technical manual.

2-9. Emergency Procedures. Any damage to the shelter walls or ceiling must be patched immediately to prevent possible water intrusion. In an emergency, any kind of tape or water-resistant materials may be used to cover a puncture or a large hole. Temporary patches must be replaced with permanent patches as soon as possible. In shielded shelter, temporary patches must be replaced as soon as possible to restore RFI/EMI suppression.

CHAPTER 3

UNIT MAINTENANCE INSTRUCTIONS

Subject	Section	Page
Lubrication	I	3-1
Repair Parts, Special Tools, TMDE, and Support Equipment	II	3-1
Service Upon Receipt	III	3-1
Troubleshooting	IV	3-7
Maintenance Procedures	V	3-11
Preparation for Shipment and Storage	VI	3-70

Section I. LUBRICATION

3-1. Lubrication Inductions. Lubricate door hinges, latches and locking mechanisms, door brace assemblies, roof access steps, and lifting and towing bracket assemblies to prevent rust and corrosion. Check these parts frequently to be sure they are adequately lubricated. Lubricate with Solid Film Lubricant, MIL-L-23398 (Item 22, Appendix D).

Section II. REPAIR PARTS, SPECIAL TOOLS, TMDE, AND SUPPORT EQUIPMENT

Subject	Para	Page
Common Tools	3-2	3-1
Special Tools, TMDE, and Support Equipment	3-3	3-1
Repair Parts	3-4	3-1

3-2. Common Tools. A complete list of common tools and tool kits is given in Section III of Appendix B, Maintenance Allocation Chart.

3-3. Special Tools, TMDE, and Support Equipment. All special tools, TMDE, and support equipment are listed in Section III of Appendix B, Maintenance Allocation Chart, and in the Repair Parts and Special Tools List manual, TM 10-5411-205-23P, S-250/G Shielded and S-250/G Unshielded Electrical Equipment Shelters.

3-4. Repair Parts. Repair parts for unit maintenance of the shelter are listed and illustrated in TM 10-5411-205-23P.

Section III. SERVICE UPON RECEIPT

Subject	Para	Page
Service Upon Receipt of Materiel.	3-5	3-1
Site Requirements	3-6	3-7

3-5. Service Upon Receipt of Materiel. Inspect the shelter for damage incurred during shipment. If the shelter has been damaged, report the damage on SF 361 Transportation Discrepancy Report (TDR). If the drain plug has been loosened for shipment, tighten it. If the shelter is crated or pallet-mounted, refer to the end item technical manual for unpacking

3-5. Service Upon Receipt of Materiel (cont).

instructions. If it is necessary for the shelter to be loaded onto a truck or transferred from one truck to another, lift, load, and secure the shelter as follows:

CAUTION

If shelter panel is punctured during loading or securing, contact direct support to repair puncture as soon as possible to prevent moisture from seeping into panels, and to restore RFI\EMI shielding in shelters having this requirement.

a. Lifting Shelter. (Figure 3-1)

- (1) Attach sling assembly to all four lifting rings on shelter so that turnbuckle ends of cables are next to lifting rings. Be sure to use correct sling assembly. (See Appendix C.)
- (2) Place sling assembly on top of shelter.
- (3) Insert lifting hook of lifting device (crane) into lifting ring.
- (4) Tie a 1/2-inch rope, at least 15 feet long, to each rear towing eye.

CAUTION

Do not jerk, bounce, or jar shelter when lifting. Avoid swinging shelter from side to side. Do not attempt to butt or push shelter into place with a forklift.

- (5) Slowly lift shelter with crane.

b. Loading Shelter onto Truck. (Figure 3-1)

WARNING

To avoid injury to personnel and damage to shelter, only personnel actually engaged in loading operation should be permitted near truck, lifting device, and shelter. To eliminate confusion, all instructions must come from loading crew supervisor.

NOTE

The entrance door of the shelter must be at the rear of the truck, and the front end of the shelter must be placed flush against the front of the truck body.

3-5. Service Upon Receipt of Materiel (cont).

Figure 3-1. Lifting and Loading Shelter

NOTE

Some procedures require the addition of dunnage to truck bed or the attachment of tiedown eyes to truck before loading shelter onto truck. Refer to TM 9-2320-280 for M1037 and M1042 trucks and TM 9-2320-289 for M1028 trucks.

- (1) Lower truck tailgate and make sure all tools and equipment have been removed from truck bed.
- (2) Position one person at free end of each rope to guide shelter into place.
- (3) Lift shelter to a position high enough to clear truck bed.
- (4) Back truck into position under shelter.

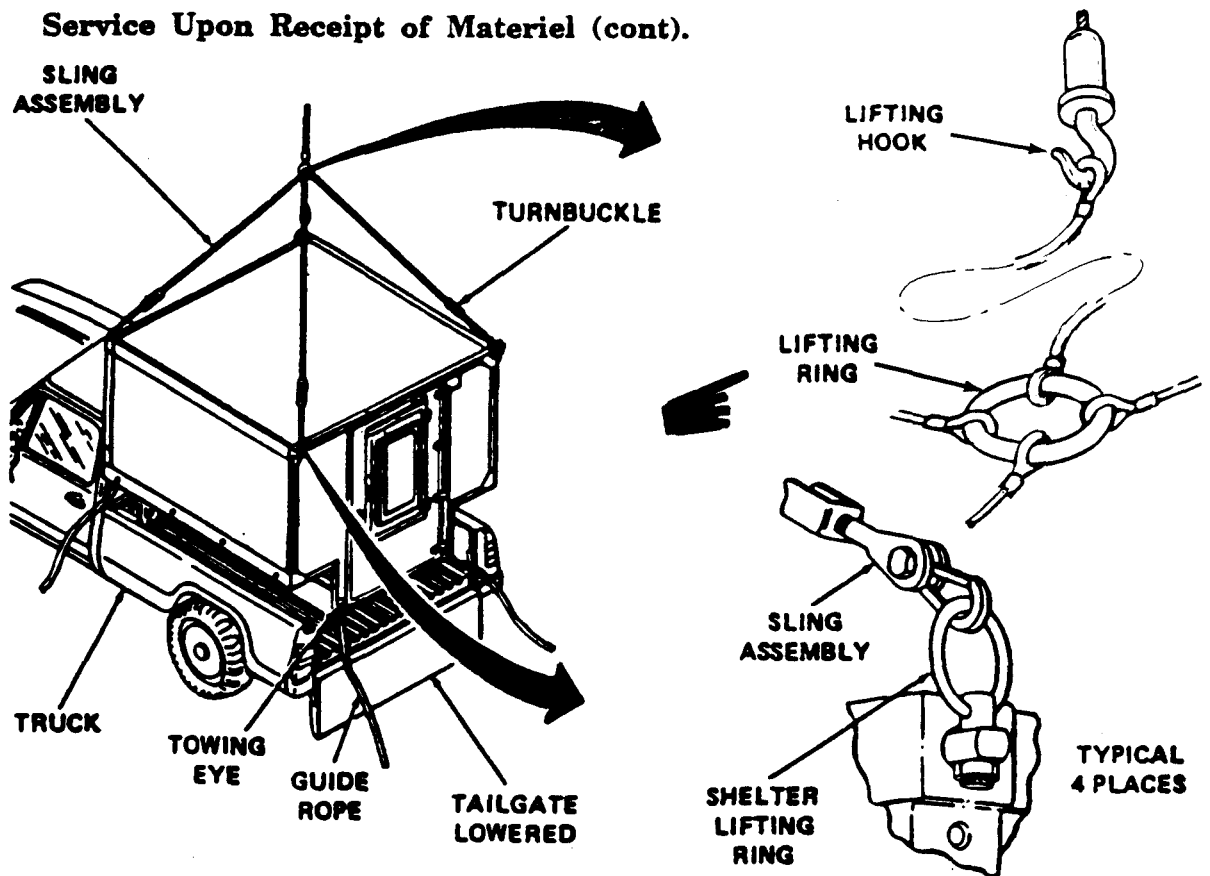
WARNING

All personnel must remain clear of truck while shelter is being lowered into place.

- (5) With one person at each rope, guide shelter into position so it is aligned above truck bed, and maintain that position while lowering shelter into place on truck.

3-5. Service Upon Receipt of Materiel (cont).

- (6) Remove lifting ring from lifting hook and separate lifting ring from sling hooks. Remove sling hooks from lifting eyes and remove ropes from rear towing eyes.

c. *Securing Shelter on 1-1/4-Ton (M561) Truck. (Figure 3-2)*

- (1) Install plate and eye bolt assemblies on cargo bed siderails of truck as described in TM 9-2320-242.
- (2) Hook ends of four sling assemblies to tiedown eyes at each top corner of shelter, using hooks at furthest end of cables from turnbuckles.

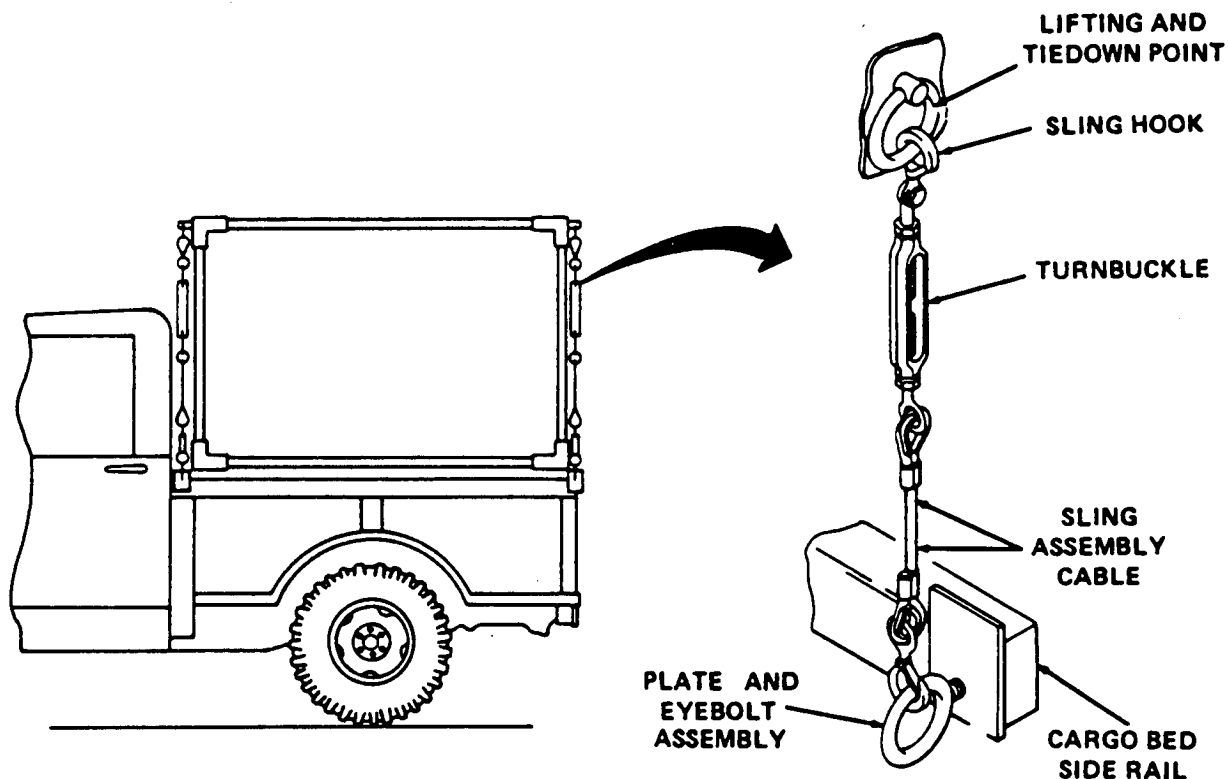

Figure 3-2. Securing Shelter on Truck.

- (3) Hook sling hooks at opposite end of cables to appropriate eye bolts on truck. Make sure sling hooks point away from shelter.
- (4) Tighten all turnbuckles evenly by hand. Then turn each turnbuckle an additional one-half turn with a bar or rod inserted in turnbuckle slot.

CAUTION

Do not overtighten turnbuckles. Overtightening may tear lifting and tiedown eyes from shelter or damage eye assembly or shelter.

3-5. Service Upon Receipt of Materiel (cont).

- (5) Insert appropriate size wooden blocks between shelter skids and sides of truck bed to prevent sideway movement strain on sling cables.
- (6) Insert appropriate size wooden blocks between shelter skids and cab wall of bed to protect cab wall and shelter towing eyes.
- (7) Raise and secure truck tailgate.

d. Securing Shelter on 1-1/4-Ton (M880) Truck.

- (1) Fabricate and install wooden dunnage in truck in accordance with Department of Army Supply Bulletin SB-11-640.
- (2) Install tiedown provisions as described in SB 11-640.
- (3) Unhook four sling legs from lifting ring of sling assembly.
- (4) Remove hooks from turnbuckle end of each sling leg.
- (5) Temporarily store lifting ring and four hooks inside shelter.
- (6) Secure hooks remaining in sling legs to four lifting eyes of shelter.
- (7) Secure turnbuckle end of sling legs to truck tiedown provisions using hardware which had been used to attach hooks to turnbuckles.

CAUTION

Do not overtighten turnbuckles. Overtightening may tear lifting and tiedown bracket assemblies from shelter or damage bracket assembly or shelter.

- (8) Tighten all turnbuckles evenly by hand. Then turn each turnbuckle an additional one-half turn with a bar or rod inserted in turnbuckle slot.
- (9) Raise and secure truck tailgate.

e. Securing Shelter on 1-1/4-Ton (M1028) Truck.

- (1) Fabricate a wooden dunnage and install wooden dunnage and tiedown provisions in truck as described in TM 9-2320-289.
- (2) Unhook four cable assemblies from sling ring assembly.
- (3) Attach each cable hook from turnbuckle end to each lifting ring of shelter.
- (4) Secure hook at other end of cable to corresponding "U" bracket on truck frame, as shown in Figure 3-3.

3-5. Service Upon Receipt of Materiel (cont).

CAUTION

Do not overtighten turnbuckles. Overtightening may tear lifting and tiedown bracket assemblies from shelter or damage bracket assembly or shelter.

- (5) Tighten all turnbuckles evenly by hand. Then turn each turnbuckle an additional one-half turn with a bar or rod inserted in turnbuckle slot.

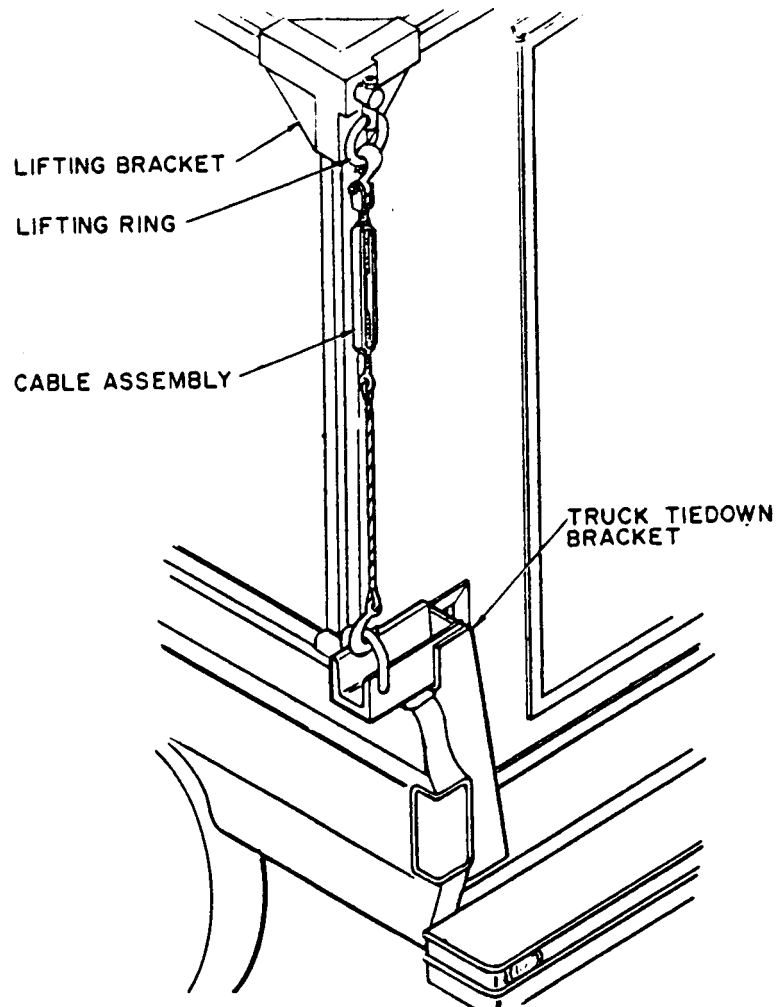

Figure 3-3. Shelter Tiedown on M1028 Truck.

3-5. Service Upon Receipt of Materiel (cont).*f. Securing Shelter on M1037 Shelter Carrier.*

- (1) To install shelter support provisions on truck bed refer to TM 9-2320-280.
- (2) Lower truck tailgate and place in loading position.
- (3) Connect sling assembly to shelter lifting brackets on the top four corners of shelter and lifting device.
- (4) Remove and retain a bolt and nut attaching each towing eye to towing bracket and remove towing eye.
- (5) Position each mounting bracket in place on towing bracket and secure with capscrew, lock washer, and flat washer, as shown in Figure 3-4. Do not tighten capscrew until shelter is installed.
- (6) Position shelter over support and gradually lower shelter onto support in truck.

NOTE

Shelter should be tightly fitted to front of support. Shims should only be added to rear shelter mounts.

- (7) Position shelter to support front mounting points. Secure shelter to front of support with four bolts, lock washers, washers, and two reinforcements. Tighten capscrews to 60 ft-lb (81 n-m). Tighten bolts to 90 ft-lb (122 n-m).
- (8) Secure rear of shelter (Figure 3-4) to support with four bolts, lock washers, washers, and two reinforcements. Do not tighten capscrews.
- (9) Add shims as necessary to rear shelter mounts to ensure snug fit between mounting brackets and support. Tighten capscrews to 60 R-lb (81 n-m). Tighten bolts to 90 ft-lb (122 n-m).
- (10) Disconnect sling from shelter.
- (11) Raise and secure tailgate.

3-6. Site Requirements. Site requirements will depend on the requirements of the equipment contained in the shelter. Refer to the end item technical manual for siting instructions.

Section IV. TROUBLESHOOTING

3-7. Troubleshooting. This section contains troubleshooting information for malfunctions which may develop in the shelter. Fault isolation is limited to those components which may be repaired or replaced at the unit or direct support level. Table 3-1 lists the common malfunctions you may encounter during operation or maintenance of the shelter. Each malfunction is followed by a list of tests or inspections and corrective actions. These tests or inspections and corrective actions should be performed in the order listed. This manual cannot list all malfunctions that may occur. If you encounter a malfunction that is not listed or that cannot be corrected by the listed corrective actions, notify your supervisor.

3-5. Service Upon Receipt of Materiel (cont).

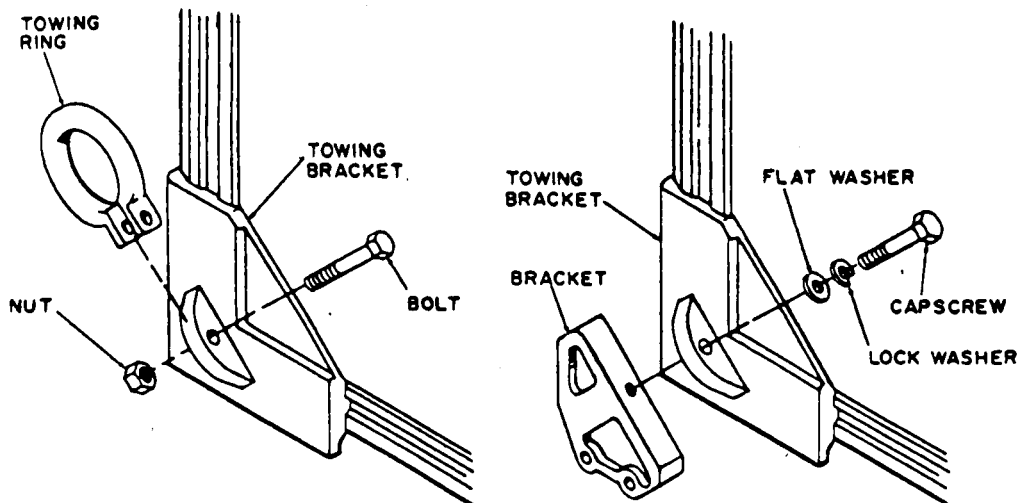

TOWING RING REMOVAL FROM TOWING BRACKET.

BRACKET INSTALLATION ON TOWING BRACKET.

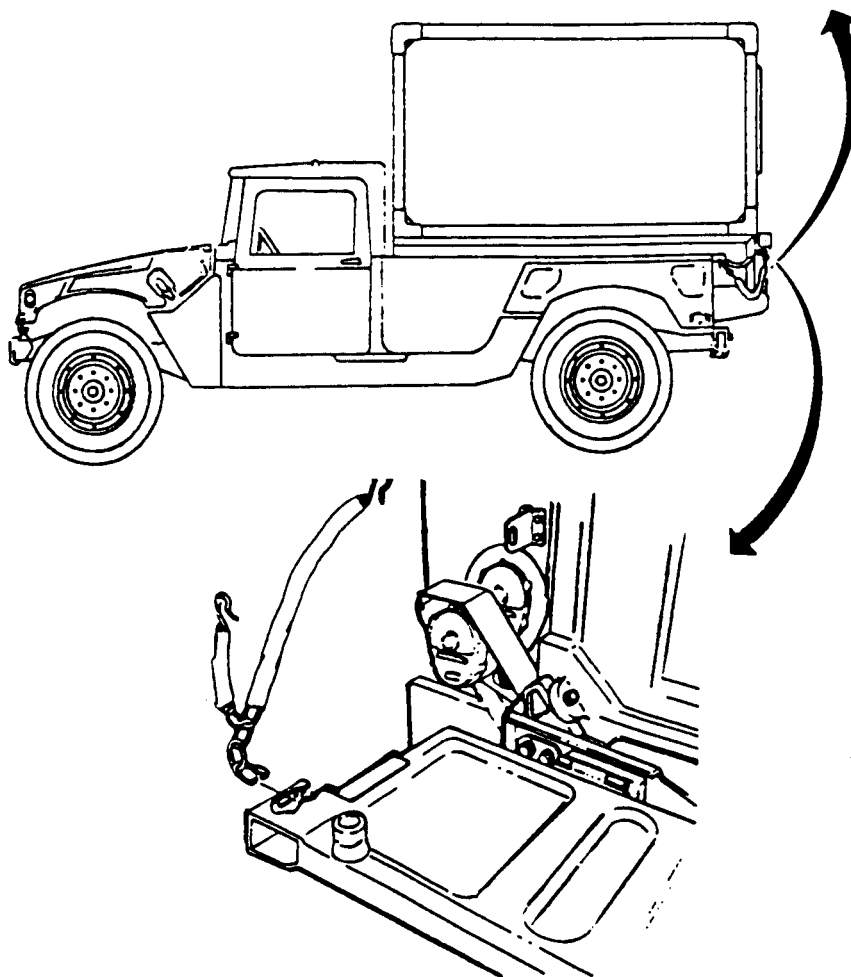

BRACKET INSTALLATION ON TOWING BRACKET.

Figure 3-4. Securing Shelter on M1037 Shelter Carrier.

Table 3-1. Troubleshooting.

MALFUNCTION	TEST OR INSPECTION	CORRECTIVE ACTION
1. OUTER DOOR OR INNER DOOR DOES NOT OPEN OR CLOSE SMOOTHLY	<p>Step 1. Inspect hinges for adequate lubrication.</p> <p style="padding-left: 40px;">Lubricate as required (paragraph 3-1).</p> <p>Step 2. Adjust or repair door as necessary (paragraph 3-19).</p>	
2. OUTER DOOR OR INNER DOOR DOES NOT STAY OPEN	<p>Step 1. Check to see if detent pin is installed in door stay channel.</p> <p style="padding-left: 40px;">Install detent pin in channel.</p> <p>Step 2. Check to see if detent pin is missing.</p> <p style="padding-left: 40px;">Install detent pin on door (paragraph 3-32.f).</p>	
3. DOOR HANDLE IS JAMMED OR DOES NOT OPERATE SMOOTHLY	<p>Step 1. Inspect components for adequate lubrication.</p> <p style="padding-left: 40px;">Lubricate as required (paragraph 3-1).</p> <p>step 2. Inspect door handle and latching mechanism for missing or damage components.</p> <p style="padding-left: 40px;">Repair or replace components as required (paragraph 3-19).</p>	
4. LOUVER COVER DOES NOT STAY OPEN	<p>Step 1. Check to see if holder assembly is attached to louver cover.</p> <p style="padding-left: 40px;">Attach holder assembly to louver cover.</p> <p>Step 2. Check to see if holder assembly is secure or damaged.</p> <p style="padding-left: 40px;">Repair or replace components as required (paragraph 3-24).</p>	
5. WATER IS GETTING INTO SHELTER	<p>Step 1. Check condition of weather gaskets around the inside edge of each door,</p> <p style="padding-left: 40px;">Replace deteriorated gaskets (paragraph 3-18).</p>	

Table 3-1. Troubleshooting (cont).

MALFUNCTION	TEST OR INSPECTION	CORRECTIVE ACTION
Step 2.	Check condition of troughs (drip moulding) above each door.	Replace defective trough (paragraph 3-12).
Step 3.	Check to see if roof access steps have pulled away from shelter wall.	Apply sealer (Item 28, Appendix D) to gaps around step flange, or replace step (paragraph 3-14).
Step 4.	Inspect shelter walls and ceiling for leaks.	If repair is required, refer to direct support.
Step 5.	Check that all exterior wall and ceiling patches are firmly mounted and bonded to shelter wall.	Apply sealer (Item 28, Appendix D) around edge of patch. If replacement of patch is necessary, refer to direct support.
Step 6.	Check if lifting bracket assemblies or towing bracket assemblies have pulled away from shelter comers.	<ul style="list-style-type: none"> a. Apply sealer (Item 28, Appendix D) to gaps around bracket edges. b. If replacement is required, notify higher level of maintenance.
6. THERE IS EVIDENCE OF RADIO FREQUENCY/ELECTROMAGNETIC INTERFERENCE.		
Step 1.	Inspect shelter walls, ceiling, and floor for holes.	If repair is required, refer to direct support.
Step 2.	Check to see that all exterior wall and ceiling patches are firmly mounted and bonded.	If replacement of patches is necessary, refer to direct support.
Step 3.	Check condition of RFI/EMI filter in door.	Replace damaged or missing falter (paragraph 3-24).

Section V. MAINTENANCE INSTRUCTIONS

Subject	Para	Page
General	3-8	3-11
General Repair Procedures	3-9	3-12
Shelter Assembly	3-10	3-21
Overall Shelter Assembly	3-11	3-23
Trough	3-12	3-25
Bail Handle	3-13	3-26
Recessed Step Pan Assembly	3-14	3-27
Drain Plug	3-15	3-29
Instruction Plates	3-16	3-30
Outer Door Assembly	3-17	3-31
Door Gaskets.....,....	3-18	3-33
Door Handle Assembly and Latching Mechanism	3-19	3-37
Keeper Assembly	3-20	3-41
Hinge Assembly	3-21	3-43
Door Hasp	3-22	3-45
Inner Door Assembly	3-23	3-46
Louver Assembly, Holder Assembly, and RFI/EMI Filter	3-24	3-48
Directional Vane Assembly and Air Intake Filter	3-25	3-51
Louver Cover Assembly Latches	3-26	3-53
Shield (Rain Flap)	3-27	3-55
Louver Cover Assembly,	3-28	3-56
Data Plates	3-29	3-58
Louver Cover Assembly Strikes.	3-30	3-59
Louver Cover Assembly Clips	3-31	3-60
Door Stay Assembly	3-32	3-61
Skid Assembly	3-33	3-63
Towing Bracket Assembly	3-34	3-67
Lifting Bracket Assembly	3-35	3-68
Sling Assembly	3-36	3-69

3-8. General. Since most shelters contain sensitive electronic equipment that cannot be easily removed, unit level maintenance and repair will primarily involve shelter exteriors or easily accessible interior areas, unless floors, ceilings or walls have evidence of water intrusion which can jeopardize operation of the equipment. The shelter shall be returned to the depot for repair if any of the following conditions exist:

- a* . Panel damages pans a structural member.
- b* . Replacement of an entire wall, ceiling, or floor is required.
- c* . Extensive equipment removal beyond the capability of the using unit is required.
- d* . Welding is required.
- e* . Damage to a structural member is severe enough to cause distortion of a wall, especially in edge or corner areas.
- f* . Lift, tow, or tiedown fittings or corner castings are damaged severely enough to indicate possible damage to the underlying structural member.

3-8. General (cont).

NOTE

If nature of damage warrants, print a caution notice using 4-inch high letters on all outside walls of the shelter as follows:
CAUTION: DAMAGED SHELTER. DO NOT SLING LIFT.

Coat threads of all screws and bolts with sealer before installing.
Coat rivet and rivnut bodies with sealer before using.

Unless otherwise noted, all procedures can be performed by one person using standard tools listed in Appendix B, Section III.

3-9. **General Repair Procedures.** The procedures described in this paragraph are general procedures that may be needed during repair *or* replacement of many of the shelter components. Wherever these general procedures apply, they are referenced at the appropriate point in the specific maintenance procedure paragraph.

a. Blind Rivet Installation and Removal. Blind rivets are used in locations where only one side of the area to be worked on is accessible. Blind pop rivets must be used in the shelter foam and beam panels, since the hammering required to install conventional rivets would damage the material. The types of rivets used in the shelter are shown in Figure 3-5 and described in Table 3-2. When installing floor patches, countersunk head rivets (styles K and T) are preferred, but dome head rivets (styles R and S) are an acceptable alternate. When installing interior wall patches, countersunk head rivets shall be used in any location in which dome head rivets will interfere with the proper installation of equipment. Closed end rivets (styles K and R) must be used for exterior repairs and floor repairs to prevent moisture and dirt from entering panels.

NOTE

Open end rivets may be used only where moisture and dirt entrance will not affect the shelter.

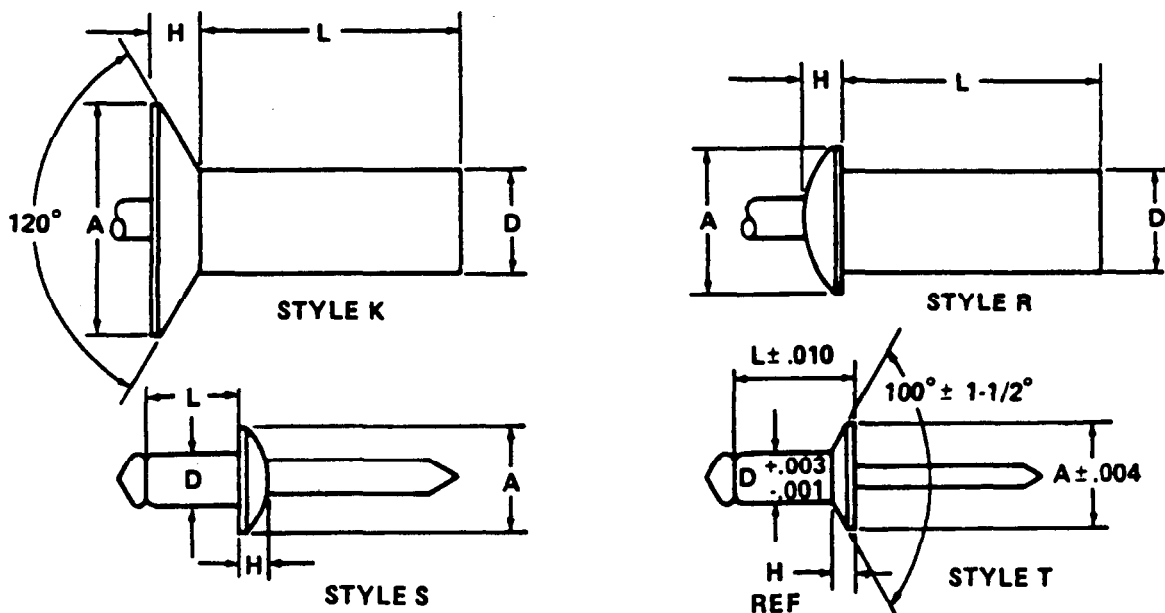

4751

Figure 3-5. Rivet Types.

Table 3-2. Blind Rivets.

Part No. 1/	Style	Dim A	Dim H	Dim D	Dim L
AD42H	R	0.236	0.051	1/8	0.361
AD43H	R	0.236	0.051	1/8	0.377
AD45H	R	0.236	0.051	1/8	0.502
AD62H	R	0.375	0.081	3/16	0.345
AD64H	R	0.375	0.081	3/16	0.470
AD68H	R	0.375	0.081	3/16	0.720
AD42S	R	0.236	0.051	1/8	0.361
MS20470AD6-8	R	0.375	0.080	3/16	0.375
NAS1398D43	R	0.250	0.067	0.156	0.326
NAS1398D4-4	R	0.250	0.067	0.156	0.388
NAS1398D6-3	R	0.375	0.080	0.187	0.350
NM1398D6-5	R	0.375	0.080	0.187	0.475
NAS1398D6-8	R	0.375	0.080	0.187	0.662
NAS1399D4-4	R	0.225	0.042	0.125	0.385
NAS1399D6-6	R	0.353	0.070	0.187	0.537
NAS1739E43	R	0.286	0.047	0.173	0.375

1/ Part Number Code Explanations

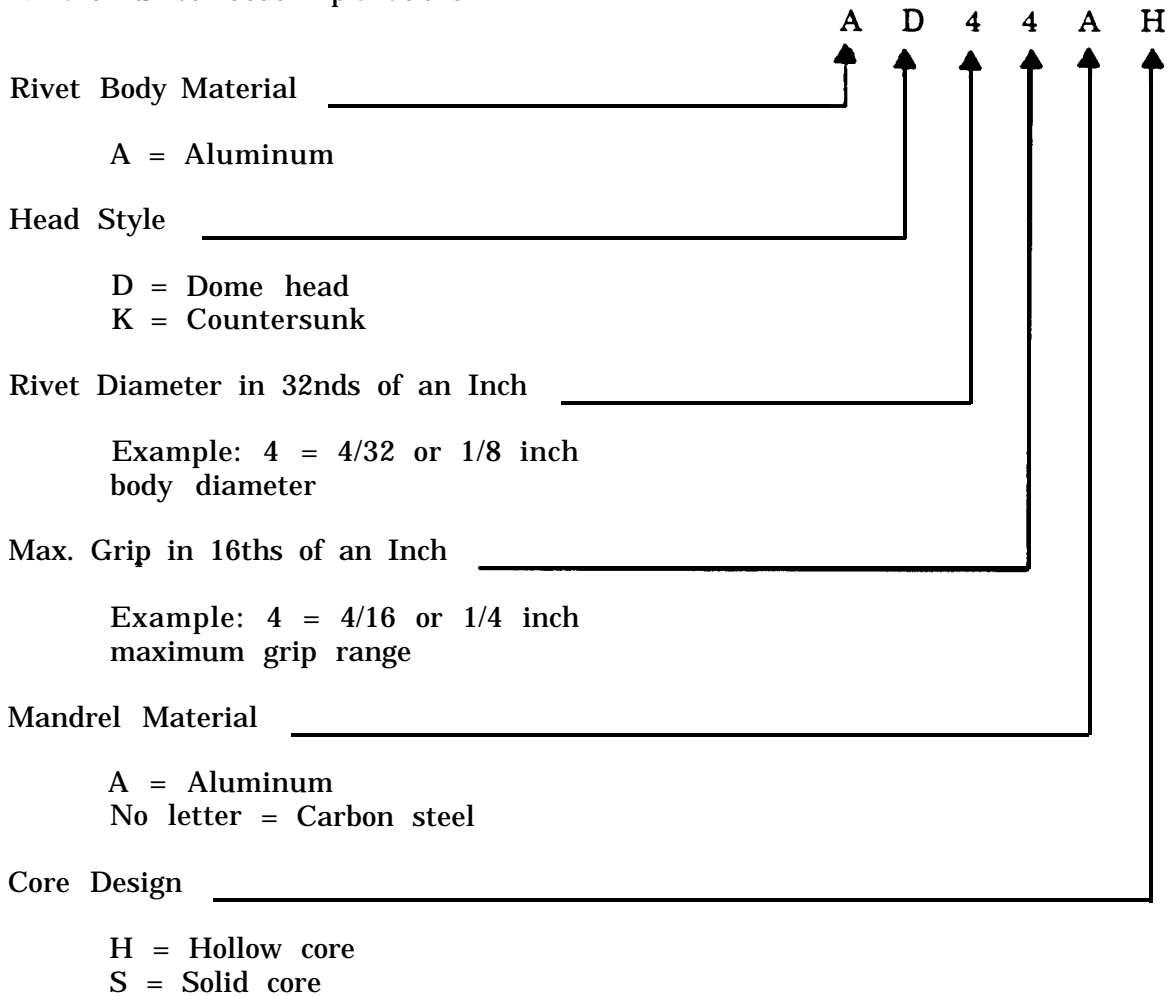

3-9. General Repair Procedures (cont).

(1) Installation. (Figure 3-6)

NOTE

When installing new rivet in same location as a rivet that has been removed and if diameter of hole in structure has been enlarged during removal of rivet, use next larger diameter rivet for replacement.

Clean rivets with solvent before installing.

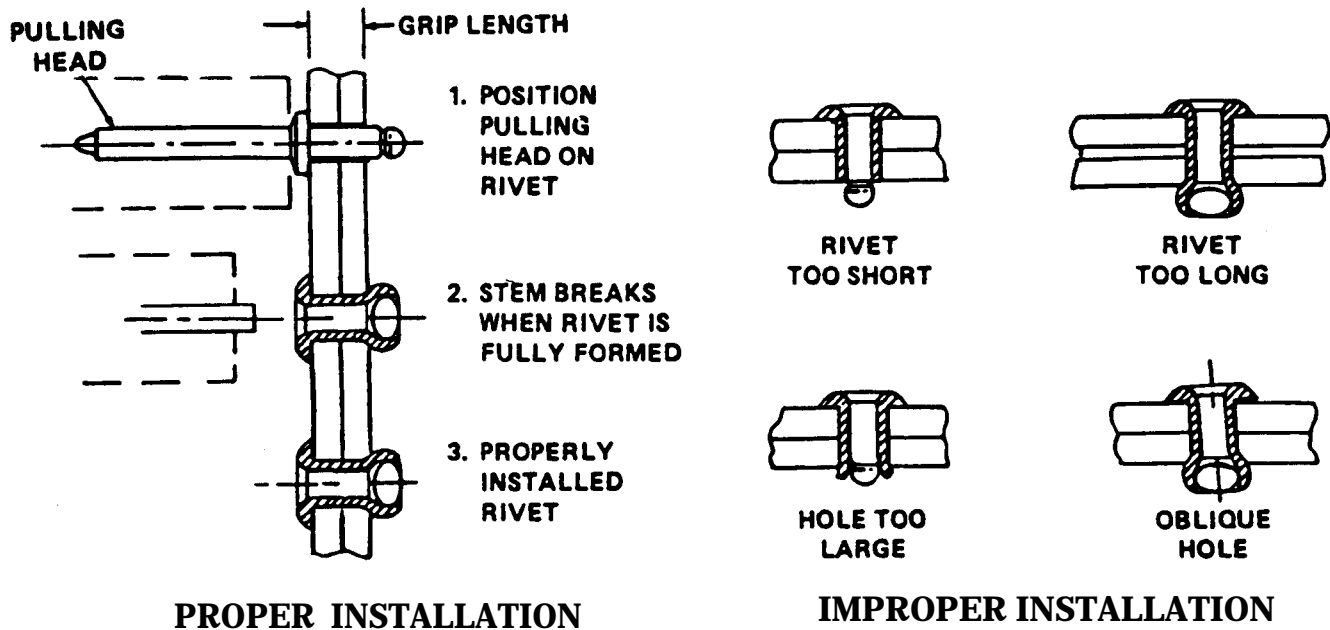

Figure 3-6. Installing Blind Rivets.

(a) Determine type, size and grip range of rivet to be used. Grip length equals combined thickness of materials being riveted together. Grip range of rivet must encompass grip length.

WARNING

Drilling creates metal chips which may enter eyes and cause serious injury. Eye protection is required.

CAUTION

Do not drill deeper than necessary to install rivet as you may drill through other side of panel.

NOTE

Drill hole size must match size of rivet being used.

Quantities of sheets may be drilled at the same time when held together with sheet fasteners.

3-9. General Repair Procedures (cont).

- (b) Drill hole in structure.
 - (c) Remove all metal chips and remove burrs from drilled holes.
 - (d) If flush head rivet is being installed, countersink hole using a 100-degree or 120-degree machine countersink.
 - (e) Coat all rivet bodies with sealer (Item 28, Appendix D) before installing.
 - (f) Insert rivet in hole. Make sure sheets are held tightly together before upsetting or pulling rivet.
 - (g) Select proper pulling head for rivet being installed and install pulling head on rivet gun.
 - (h) Insert stem of rivet into pulling head.
 - (i) With pulling head parallel to axis of rivet, upset rivet. Exert firm pressure but do not bend or buckle metal sheets. Stem will break off below rivet head surface. No trimming should be required.
 - (j) Make sure riveted parts are not loose, rivet does not rotate, and rivet head is seated tightly against riveted surface. If rivet is loose or improperly installed, remove it and install a new one.
- (2) *Removal. (Figure 3-7)*

WARNING

Drilling creates metal chips which may enter eyes and cause serious injury. Eye protection is required.

NOTE

When drilling through rivet head, be careful to avoid enlarging hole in structure. Keep drill perpendicular to material being drilled and do not exert excessive pressure on drill, or replacement rivets will be too loose.

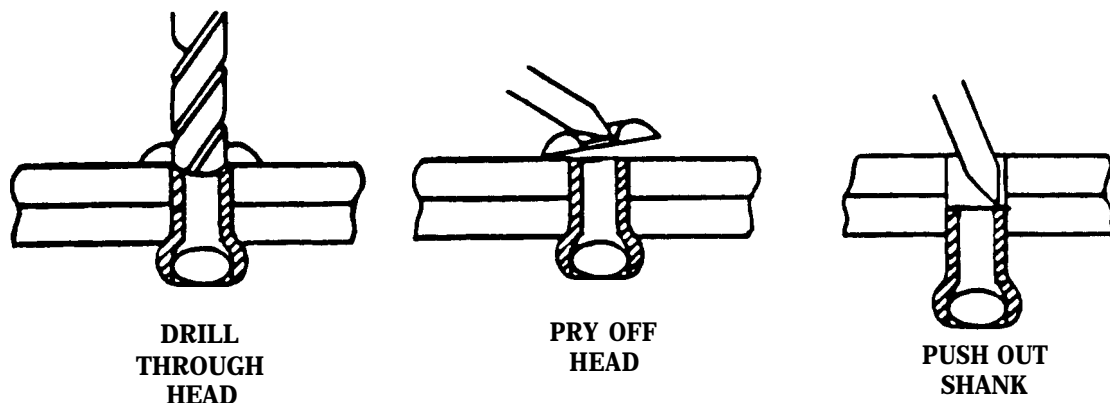

Figure 3-7. Removing Blind Rivets,

3-9. General Repair Procedures (cont).

(a) Drill through head of rivet only. using hole in rivet as a guide. Use proper drill size as follows:

Rivet Size (in.)	Drill size
1/8	No. 30
5/32	No. 20
3/16	No. 11
1/4	1/4 inch

(b) Using a pin punch, pry off rivet head.

CAUTION

Do not punch rivet shanks out as you may damage the other side of the panel.

(c) Using pin punch, push out remainder of rivet shank. If shank will not push out easily, drill it out.

b. Rivnut Installation and Removal. Rivnuts (threaded inserts) are tubular rivets with internal threads and are used throughout the shelter wherever blind threads are required. The types of rivnuts used in the shelter are shown in Figure 3-8 and described in Table 3-3. Flat head rivnuts (style D and E) may be used wherever head thickness will not interfere with installation of equipment. Countersunk head rivnuts (style C) are used for flush installation. Keyed rivnuts are used in locations which are subject to vibration and torque. Closed end rivnuts (styles C and E) must be used for all interior or exterior repairs to keep moisture and dirt from entering panels. Open end rivnuts (style D) maybe used only where rivnut to be replaced is open end and not subject to water penetration.

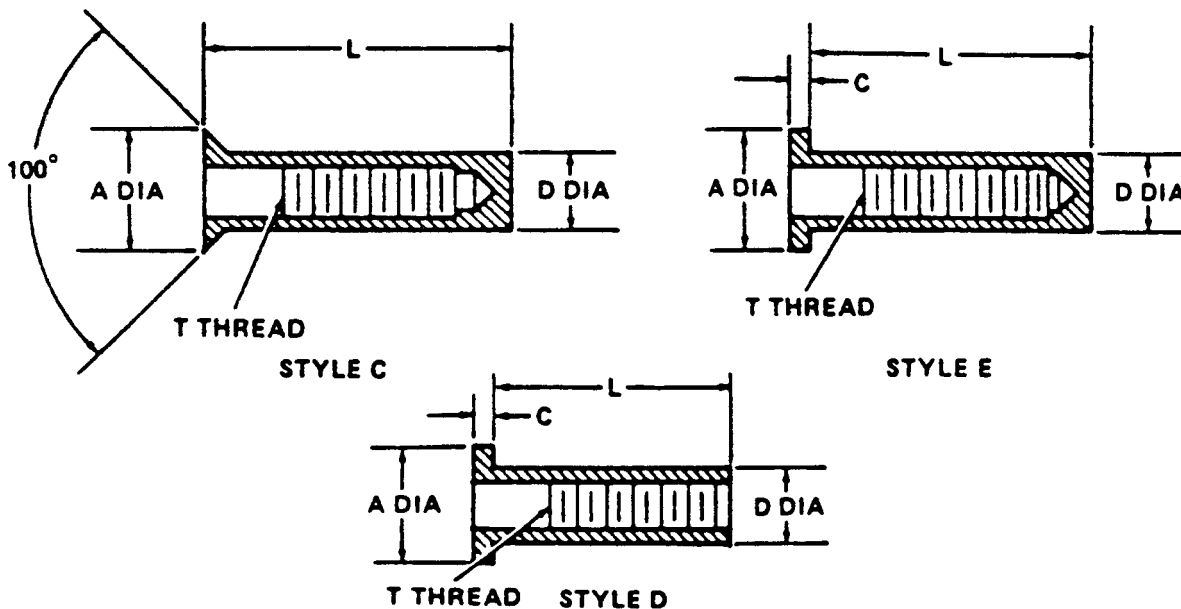

Figure 3-8. Rivnuts (Threaded Inserts).

Table 3-3. Rivnuts.

Dash No.	Part No.	Style	Dim A	Dim D	Dim L	T	Dim C	Grip Range
SM-C-563711-1	S25B151	C	0.529	0.332	1.000 "	1/4-20 UNC-3B		.089-.151
SM-C-563711-2	S25B211	C	0.529	0.332	1.062	1/4-20 UNC-3B		.151-.211
SM-C-563711-3	S25B451	C	0.529	0.332	1.312	1/4-20 UNC-3B		.391-.451
SM-C-563711-4	S10B366	C	0.391	0.250	1.094	10-32 UNC-3B		.316-.366
SM-C-563711-5	S25B140	E	0.475	0.332	1.000	1/4-20 UNC-3B	0.058	.080-.140
SM-C-563711-6	S8B106	C	0.355	0.221	0.687	8-32 UNC-3B		.065-.106
SM-C-563711-7	S31B350	D	0.665	0.413	1.032	5/16-18 UNC-3B	0.062	.275-.350
SM-C-563711-8	S31B125	E	0.666	0.413	1.187	5/16-18 UNC-3B	0.062	.030-.125
SM-C-563711-9	S31B481	C	0.656	0.413	1.562	5/16-18 UNC-3B		.406-.481
SM-C-563711-10	S8B201	C	0.355	0.221	0.687	8-32 UNC-3B		.161-.201
SM-C-563711-11	S8B161	C	0.355	0.221	0.687	8-32 UNC-3B		.106-.161
SM-C-563711-12	S25B320	E	0.475	0.332	1.187	1/4-20 UNC-3B	0.058	.260-.320
SM-C-563711-13	S31B425	E	0.665	0.413	1.531	5/16-18 UNC-3B	0.062	.350-.425
SM-C-563711-14	S81B350	E	0.665	0.413	1.437	4/16-18 UNC-3B	0.062	.275-.350

(1) Installation. (Figure 3-9)

NOTE

When installing new rivnut in same location as a rivnut that has been removed, if diameter of hole in structure has been enlarged during removal, use next larger diameter rivnut for replacement.

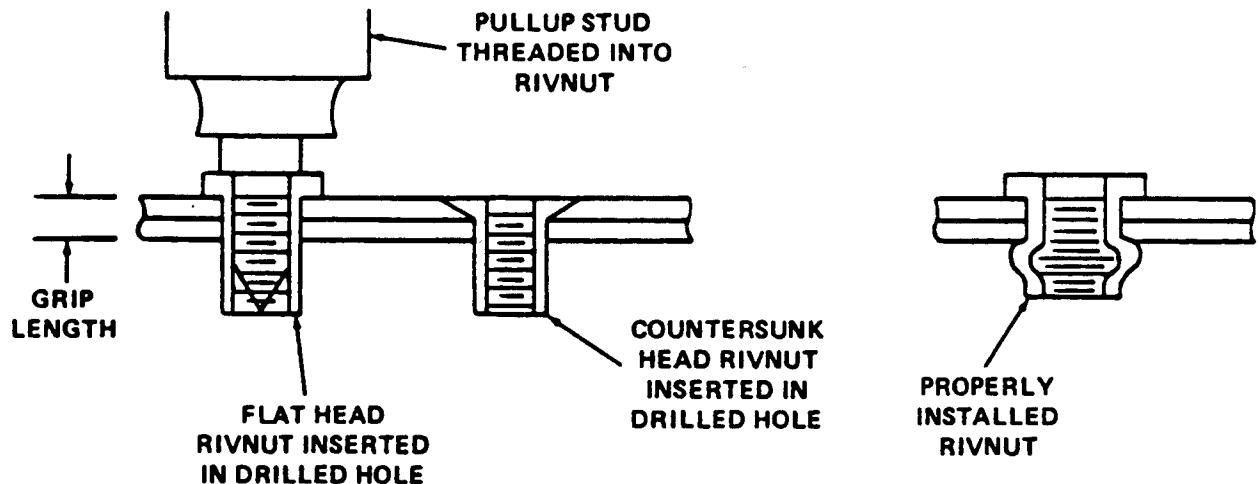

Figure 3-9. Installing Rivnuts.

3-9. General Repair Procedures (cont).

- (a) Determine thread size, grip range, style, and material of rivnut to be used. Grip length equals combined thickness of materials being fastened together. Grip range of rivnuts must encompass grip length.

WARNING

Drilling creates metal chips which may enter eyes and cause serious injury. Eye protection is required.

CAUTION

Do not drill deeper than necessary to install rivet as you may drill through other side of panel.

NOTE

Drill hole size must match size of rivnut being installed. Quantities of sheets may be drilled at the same time when held together with sheet fasteners.

- (b) Drill hole in structure.
- (c) Remove all metal chips and remove burrs from drilled holes.
- (d) If a countersunk head rivnut is being installed, countersink hole using a 100-degree machine countersink.
- (e) Thread stem of appropriate pullup stud into rivnut. Stud should protrude through open end rivnuts, or be 1-1/2 threads from bottoming in closed end rivnuts.
- (f) Coat rivnut body with sealer before installing.
- (g) Insert rivnut in hole. Make sure sheets are held tightly together before pulling.
- (h) With pullup stud parallel to axis of rivnut, pull up on rivnut. Exert firm pressure but do not bend or buckle metal sheets.
- (i) Make sure fastened parts are not loose, rivnut does not rotate and rivnut head is seated tightly against surface. Make sure rivnut threads are in good condition. If threads are damaged or rivnut is improperly installed, remove it and install a new one.

3-9. General Repair Procedures (cont).**(2) Removal (Figure 3-10)****WARNING**

Drilling creates metal chips which may enter eyes and cause serious injury. Eye protection is required.

(a) Drill through head of rivnut, using same size drill used to make original hole. Counterbore in rivnut will act as a drill guide.

(b) Remove head of rivnut.

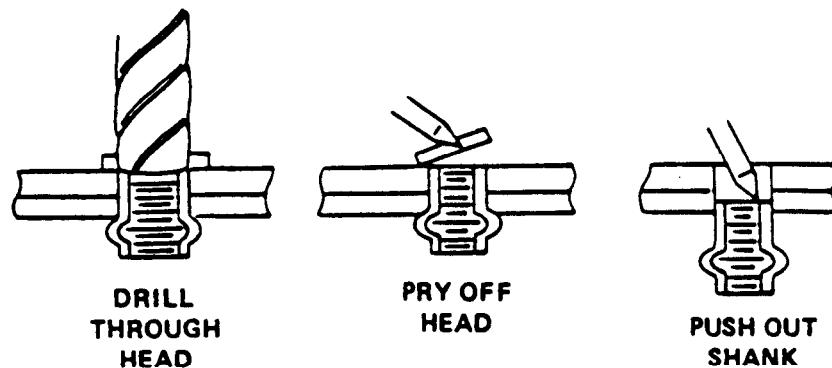

Figure 3-10. Removing Rivnuts.

CAUTION

Do not puncture opposite face sheet of panel when punching out rivnut shank.

(c) Punch out shank of rivnut, using a pin punch slightly smaller than hole in structure. Punch only enough to disengage. Move rivnut aside to install new rivnut.

(3) *Repair.* (Figure 3-11) When excessive torque is applied on screws attached on rivnuts, it may cause a rivnut to turn (spin). Table 3-4 provide the maximum torque requirement for hardware to prevent rivnut turning. To correct a turning rivnut, proceed as follows:

(a) Drill a .062 (+.003, -.001) diameter hole by 1.00 inch long on the stem of the turning rivnut as shown in Figure 3-11.

(b) Install a headless straight pin (Item 25, Appendix D) in hole.

3-9. General Repair Procedures (cont).

Table 3-4. Maximum Torque Requirement for Rivnut Screws.

Screw Size	Torque (lbs/inch)
4 - 40	8 inch lb
6 - 32	12 inch lb
8 - 32	20 inch lb
10 - 32	20 inch lb
1/4 - 20	50 inch lb
5/16 - 18	65 inch lb
3/8 - 16	120 inch lb

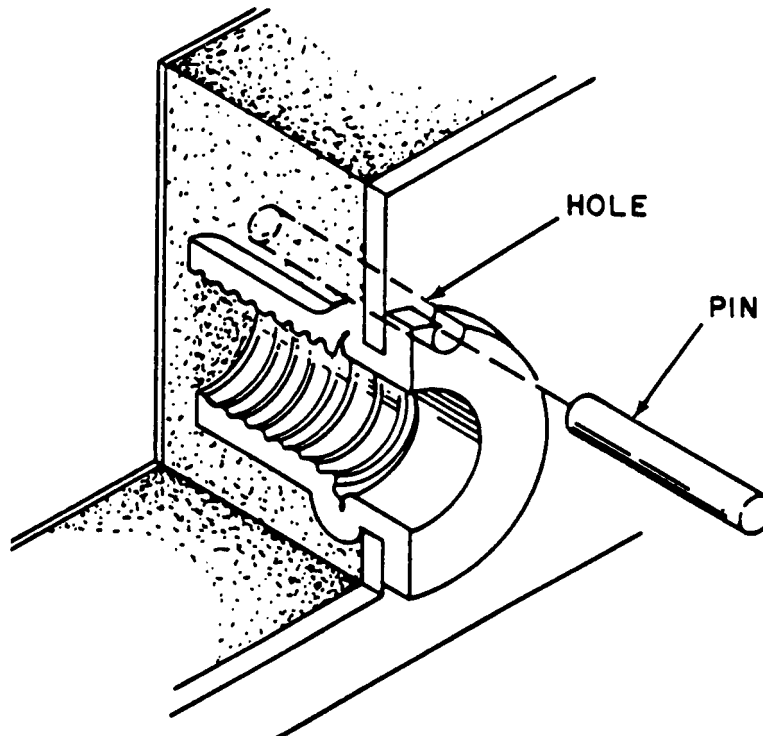

Figure 3-11. Repair of Turning Rivnut

c. Temporary Panel Repair. Any puncture in the shelter exterior, including punctures in the door skin, must be patched immediately to prevent water intrusion. Dents without punctures do not require patching. However, if bare metal is exposed, touch-up paint shall be applied (paragraph 3-9.d).

Materials/Parts Adhesive (Item 30, Appendix D)
 Tape, Polyethylene (Item 29, Appendix D)
 Sandpaper, Grit Nos. 60 (Item 15, Appendix D)

Sealer, Silicone (Item 26, Appendix D)
 Clean Cloth, Cotton (Item 10, Appendix D)
 Solvent (Item 9, Appendix D)
 Gloves (Item 1, Appendix D)

3-9. General Repair Procedures (cont).**WARNING**

Solvents are flammable and toxic. Keep away from heat and open flames. Use in a well-ventilated area. Avoid skin and eye contact and breathing of vapors. Use protective goggles and gloves.

CAUTION

Paint strippers can contaminate panel core, adhesive, and sealers. Do not use paint strippers to remove paint.

NOTE

Ceiling and floor panel compositions are the same as wall panel composition. The same method of repair applies to all panels.

- (1) Bend edges of puncture in below surface of unbroken face sheet. Do not allow broken edges to contact opposite face sheet.
- (2) Remove loose fragments of foam and dust.
- (3) Clean and dry area surrounding puncture using clean cloth soaked with solvent. Wipe off solvent.
- (4) Inject adhesive into puncture and fill.
- (5) Apply a bead of adhesive approximately 1/4 inch wide over cuts in face sheet. Do not smooth out.
- (6) Plan application of tape. Length and width, number of strips, overlaps, and method of application will affect sealing capability of repair. Each piece of tape shall extend approximately 1-1/2 inches beyond adhesive. Tape must be applied to bare clean metal. If width of damaged area exceeds width of tape, overlap tape strips at least 1/2 inch. If three or more strips of tape are required, apply center strip first.
- (7) Stretch tape and apply lightly. Do not apply with rolling motion from end to end or side to side and do not rub strips into place. Tape strips must tightly adhere to each other. Rolling, rubbing, and excessive pressure will squeeze adhesive out from under tape.
- (8) Touch up with paint as required (paragraph 3-9.d).

d. Touch-up painting. When required, to prevent rust and corrosion, touch up small areas of damaged or chipped paint in accordance with TM 43-0139. If large areas need repainting, notify higher level of maintenance.

3-10. Shelter Assembly. Shelter Assembly maintenance consists of the following

- a.* Overall shelter assembly inspection (paragraph 3-11).

3-10 Shelter Assembly (cont).

- b.* Trough (above each door) replacement (paragraph 3-12).
- c.* Bail handle (roof) replacement (paragraph 3-13).
- d.* Recessed step pan assembly replacement (3-14).
- e.* Drain plug replacement (paragraph 3-15).

3-11. Overall Shelter Assembly.

This task covers: Inspect

INITIAL SETUP*Tools*

General Mechanic's Automotive Tool Kit

Inspect. (Figure 3-12)

- (1) Inspect shelter exterior for dents, punctures, or any other damage.
- (2) Inspect shelter exterior for missing or loose parts and mounting hardware.
- (3) Inspect outer door assembly (1) and inner door assembly (2) for ease of operation.
- (4) Inspect louver cover assembly (3) for missing or damaged hardware and for ease of opening.
- (5) Inspect bail hand (4) and recessed steps (5) on shelter exterior for loose, missing, or damaged parts, and for proper operation.
- (6) Inspect towing eye bracket assembly (6) for damaged or missing parts and for proper operation.
- (7) Inspect lifting eye bracket assembly (7) for damaged or missing parts, and for proper operation.
- (8) Inspect sling assembly for damaged or missing parts, and for proper operation.
- (9) Inspect door latching mechanism (8), keeper assembly (9), and door stay assembly (10) for damaged or missing parts, and for proper operation.
- (10) Inspect skid assembly (11) for damaged or missing parts.

3-11. Overall Shelter Assembly (cont).

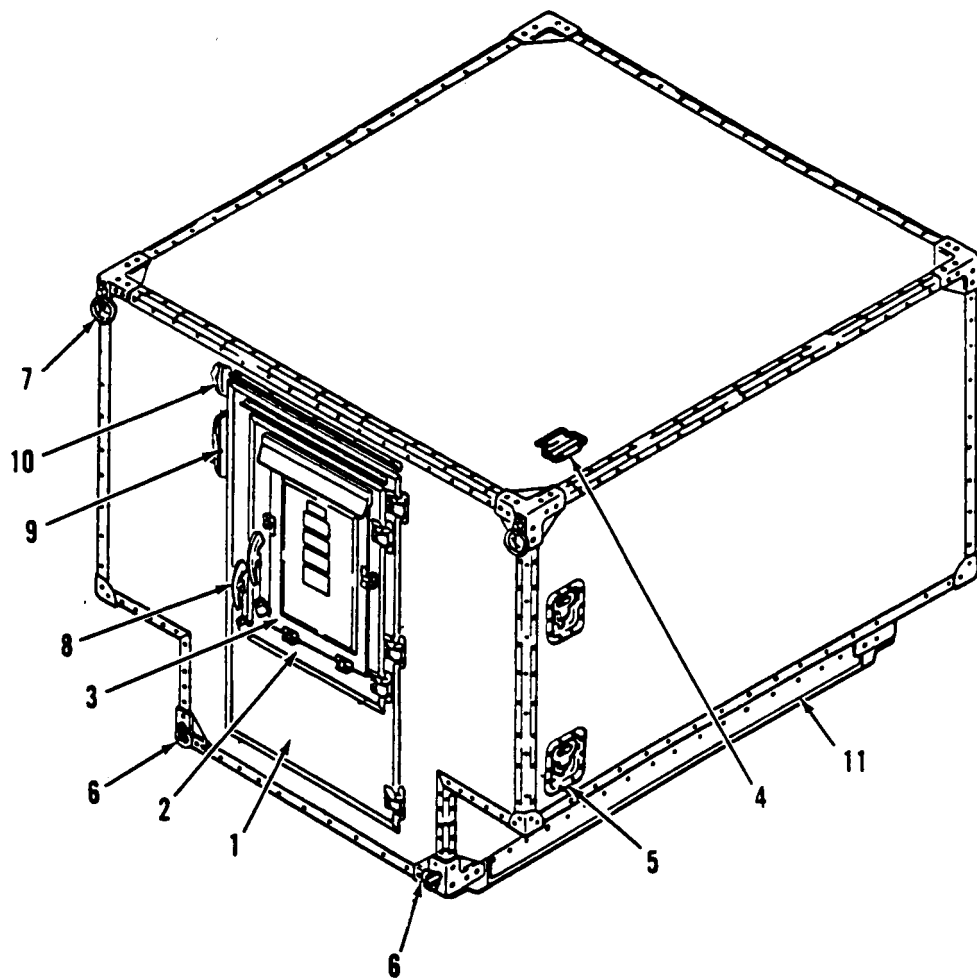

Figure 3-12. Overall Shelter Assembly Inspection.

3-12. Trough

This task covers Replace

INITIAL SETUP

Tools

General Mechanic's Automotive Tool Kit

Materials/Parts

Sealer (Item 28, Appendix D)

Replace. (Figure 3-13)

NOTE

The trough mounted to the shelter rear panel just above the door is identical to the trough on the outer door except that the rear panel trough is longer and is mounted with six screws instead of five.

- (1) Remove five tapping screws (1) mounting trough (2) to outer door (3).
- (2) Take trough (2) off door (3).
- (3) Apply sealer to back of trough (2).
- (4) Position trough (2) on top edge of outer door (3).
- (5) Dip in sealer and install five tapping screws (1), and coat heads of screws with sealer.

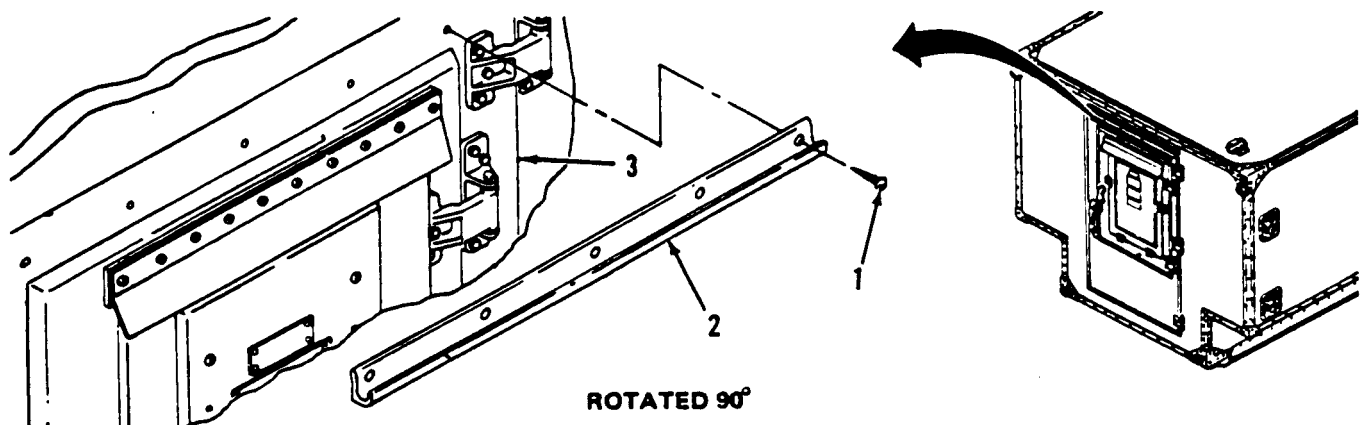

Figure 3-13. Trough Replacement.

3-13. Bail Handle.

This task covers: Replace

INITIAL SETUP

Tools

General Mechanic's Automotive Tool Kit

Materials/Parts

Sealer (Item 28, Appendix D)
Rivets, Various

Replace. (Figure 3-14)

- (1) Drill out five rivets (1). (Refer to paragraph 3-9.a for rivet removal instructions.)
- (2) Take bail handle (2) off shelter roof.
- (3) Position bail handle (2) on shelter roof.
- (4) Fasten with five rivets (1). (Refer to paragraph 3-9.a for rivet installation instructions.)
- (5) Apply a bead of sealer around edge of bail handle (2) and coat heads of rivets with sealer.

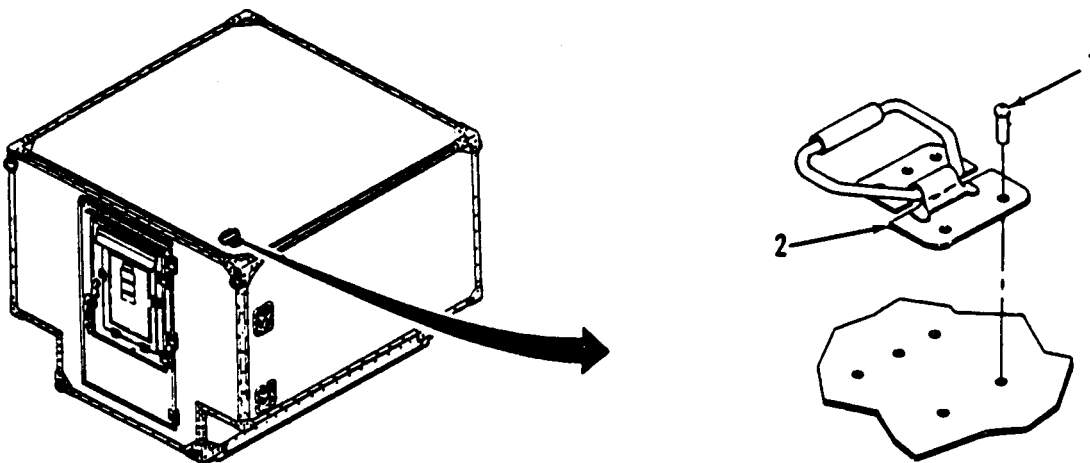

Figure 3-14. Bail Handle Replacement.

3-14. Recessed Step Pan Assembly.

This task covers: Replace

INITIAL SETUP*Tools*

General Mechanic's Automotive Tool Kit

Materials/Parts

Conductive Compound (Item 33,
Appendix D)
Sealer (Item 28, Appendix D)

Replace. (Figure 3-15)

- (1) Pull step (1) out and down to operating position.
- (2) Remove two attaching locknuts (2) and remove step (1).
- (3) Remove and retain ten phillips head screws (3) and lock washers (4) attaching recessed step pan (5) to shelter wall and remove pan.
- (4) If rivnuts (6) are damaged, remove and replace. (Refer to paragraph 3-9. b.)
- (5) Apply conductive compound to shelter wall where it will mate with flange of
- (6) position recessed step pan (5) in place on shelter wall and secure with ten phillips head screws (3) and lock washers (4).
- (7) Position step (1) in place over mounting studs in recessed pan (5) and secure with two locknuts.
- (8) Apply a continuous bead of sealer around edge of recessed step pan (5).

3-14. Recessed Step Pan Assembly (cont).

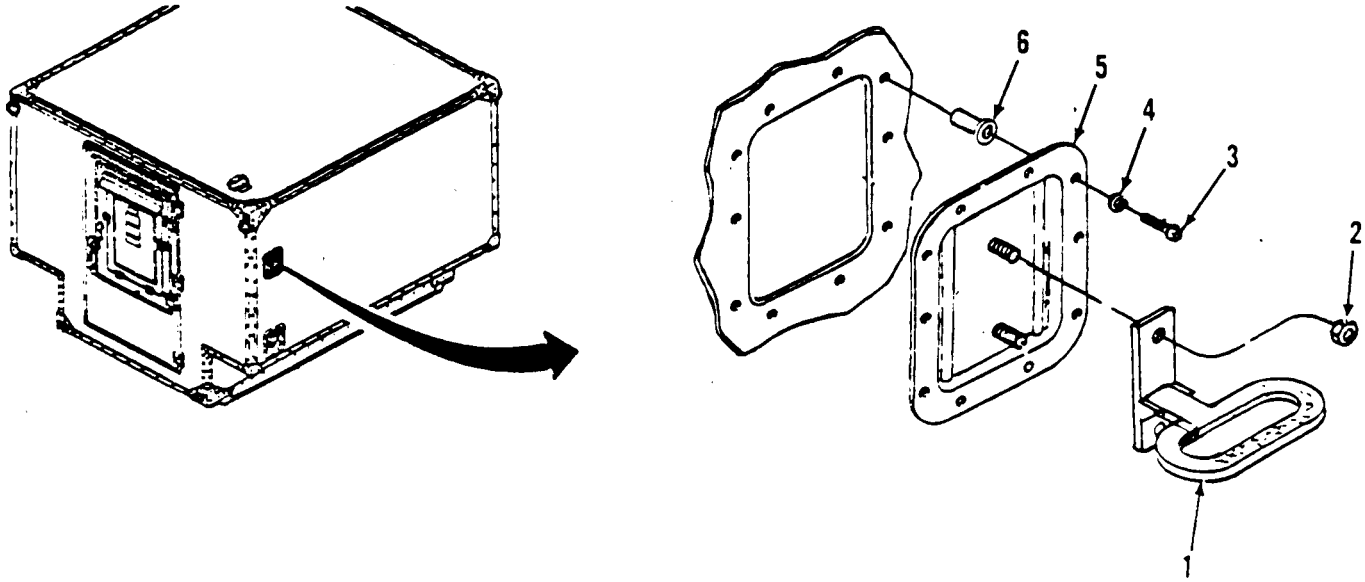

Figure 3-15. Recessed Step Pan Assembly Replacement.

3-15. Drain Plug.

This task covers: Replace

INITIAL SETUP*Tools*

General Mechanic's Automotive Tool Kit

Materials/Parts

Sealer (Item 28, Appendix D)

Replace. (Figure 3-16)

- (1) Remove screw (1) attaching drain plug chain (2) to cover (3).
- (2) Pull plug (4) out of drain.
- (3) Install plug (4) firmly in drain.
- (4) Dip screw (1) in sealer and attach tab of chain (2) to cover (3).

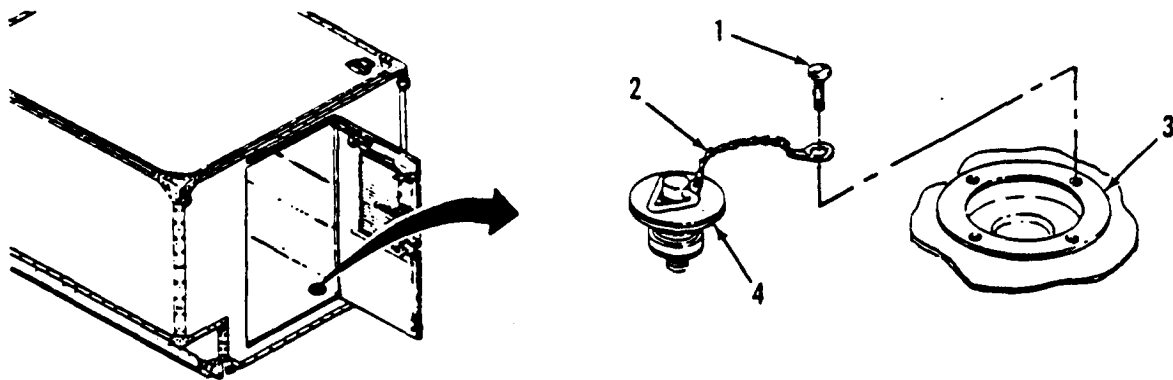

Figure 3-16. Drain Plug Replacement.

3-16. Instruction Plates.

This task covers Replace

INITIAL SETUP

Tools

General Mechanic's Automotive Tool Kit

Materials/Parts

Sealer (Item 28, Appendix D)

Replace. (Figure 3-17)

- (1) Remove four tapping screws (1)
- (2) Take plate (2 or 3) off door (4)
- (3) Position plate (2 or 3) on door (4).
- (4) Dip in sealer and install four tapping screws (1).

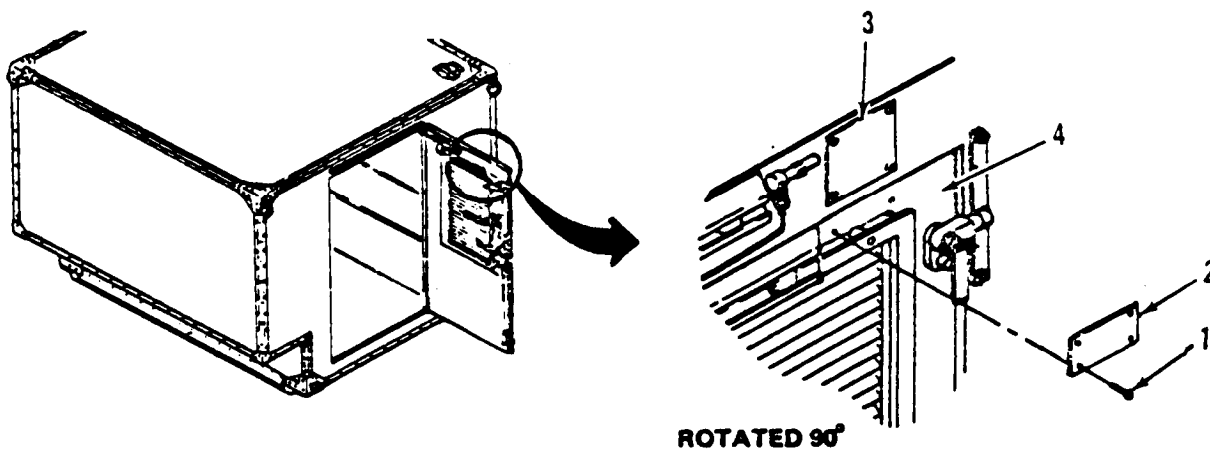

Figure 3-17. Instruction Plate Replacement

3-17. Outer Door Assembly.

This task covers

- a. Inspect
- b. Remove
- c. Repair
- d. Install

INITIAL SETUP

Tools

General Mechanic's Automotive Tool Kit

Materials/Parts

Sealer (Item 28, Appendix D)
Conductive Compound (Item 33,
Appendix D)

a. Inspect. (Figure 3-18)

- (1) Inspect the outer door assembly (6) for external damage.
- (2) Inspect the silicone weather gasket (8) for tightness.
- (3) Inspect the RFI/EMI gasket (9) for wear and secure mounting on shielded shelter.
- (4) Inspect the door for positive closing and proper operation.

b. Remove. (Figure 3-18)

- (1) Remove and retain three phillips head screws (1) attaching door stay channel (2) to door panel, and pull channel away from door panel.
- (2) Remove and retain four nuts (3), lock washers (4), and hex head screws (5) attaching each of the three hinges to shelter.
- (3) Remove outer door panel (6) and three hinge spacers (7).

c. Repair. Outer door assembly repair consists of the following

- (1) Door gasket (silicone and RFI/EMI) replacement (paragraph 3-18).
- (2) Door handle assembly and latching mechanism replacement (paragraph 3-19).
- (3) Keeper replacement (paragraph 3-20).
- (4) Hinge assembly replacement (paragraph 3-21).

3-17. Outer Door Assembly (cont).

(5) Door hasp replacement (paragraph 3-22).

a . Install. (Figure 3-18)

- (1) Coat both sides of each hinge spacer (7) with conductive compound.
- (2) Position each spacer (7) and outer door assembly (6) in place and secure each hinge to shelter with four hex head screws (3), lock washers (4), and nuts (5).
- (3) Position door stay assembly channel (2) in place and secure to outer door panel (6) with three phillips head screws (1).
- (5) Apply a continuous bead of sealer around spacer (7) and hinge bracket, and around head of screws (5).

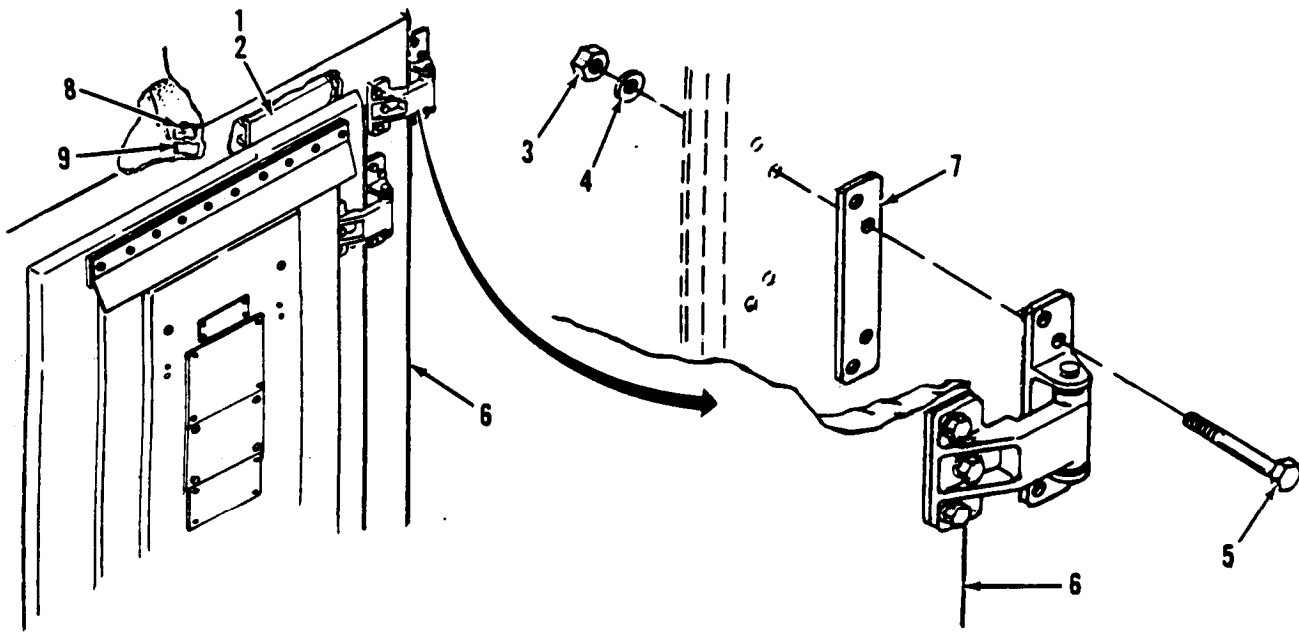

Figure 3-18. Outer Door Assembly Replacement.

3-18. Door Gaskets.

- This task covers:
- a. Inspect
 - b. Test
 - c. Adjust
 - d. Replace

INITIAL SETUP

Tools

Materials/Parts

General Mechanic's Automotive Tool Kit

Silicone Sealer (Item 26, Appendix D)
 Gasket, Silicone (Item 27, Appendix D)
 EMI/RFI Gasket (Item 31, Appendix D)
 Conductive Compound (Item 33, Appendix D)

NOTE

RFI/EMI gaskets are only on outer and inner doors of shielded shelters.

a. Inspect. (Figure 3-20)

- (1) Inspect the door assembly (2) for external damage.
- (2) Inspect the silicone weather gasket (15) for tightness.
- (3) Inspect the RFI/EMI gasket for wear and secure mounting.

b. Test. (Figure 3-19) Test of the door assembly consists of testing for proper seal pressure on the silicone weather gasket. The procedure listed below shall be performed at the center top and bottom of the door, and three places along each side of the door, as shown in Figure 3-19.

- (1) Place a single piece of paper (0.005 inches maximum thickness by 2-1/2 inches wide) between the silicone weather gasket and its bearing surface.
- (2) Close and lock the door.

NOTE

The absence of any resistance to the withdrawal of the paper indicates that the gasket is not touching its bearing surface, thus indicating insufficient pressure.

3-18. Door Gaskets (cont).

- (3) Withdraw the paper. Resistance to the withdrawal of the paper indicates proper seal pressure. If there is no resistance, perform the adjustment procedure contained in the following paragraphs.
- (4) If there is resistance to the withdrawal at all of the test points, sufficient seal pressure exists on the silicone weather gasket and adjustments are not necessary.

c . Adjust. (Figure 3-20) Adjustment to increase the seal pressure on the silicone weather gasket can be made on the hinged side of the door and on the roller latch side of the door, as described in the following paragraphs:

- (1) Weather Gasket Pressure Adjustment. To increase the weather gasket pressure on the hinged side of the door, proceed as follows
 - (a) Open the door and remove and retain three bolts (1), six flat washers (2), and three self-locking nuts (3) attaching the hinge to the door.
 - (b) Coat each new shim with conductive compound on both sides.
 - (c) Insert shim (4), approximately 0.032 inches thick and matching the hinge body in size, between the hinge leaf and the door.
 - (d) Secure the hinge leaf to the door using three bolts (1), six flat washers (2), and three self-locking nuts (3).
 - (e) Repeat the test procedures of paragraph 3-18.b. and repeat this adjustment procedure as necessary.
 - (f) After completion of adjustment procedure, apply a continuous bead of sealer around shim (4) and hinge leaf, and around head of bolts (1).
- (2) Seal Pressure Adjustment. To increase the seal pressure on the roller latch side of the door, proceed as follows
 - (a) Open the door and remove and retain the hex head screws (5 and 6), flat washers (7), and lock washers (8) from the top and bottom hole attaching the keeper (9) to the wall, and remove keeper and shim (10). Remove detent pin (11) from center keeper.

NOTE

If more than one shim (12) is required, additional shims may be added, up to a maximum thickness of 0.096 inches.

If the seals are not tight after the maximum allowable thickness is obtained, the seal should be replaced as the material has likely broken down.

- (b) Add a 0.032 inch shim between the keeper (9) and the shelter.

3-18. Door Gaskets (cont).

- (c) Repeat the seal pressure test of paragraph 3-18.b. If the seal pressure remains insufficient, add another 0.032 inch shim.
- (d) Repeat this process until sufficient seal pressure is developed or until the maximum allowable thickness is obtained.

d. **Replace.** (Figure 3-20) To replace the RFI/EMI gasket (13), remove gasket from track and clean track of any dirt. Place new gasket over track and snap in place. To replace the silicone weather gasket (14), proceed as follows

- (1) Remove gasket (14) and clean track from adhesive residue.
- (2) Apply sealer in track groove all around door and snap new gasket in place in track on door.

CAUTION

Allow at least 30 minutes cure time for adhesive before using door.

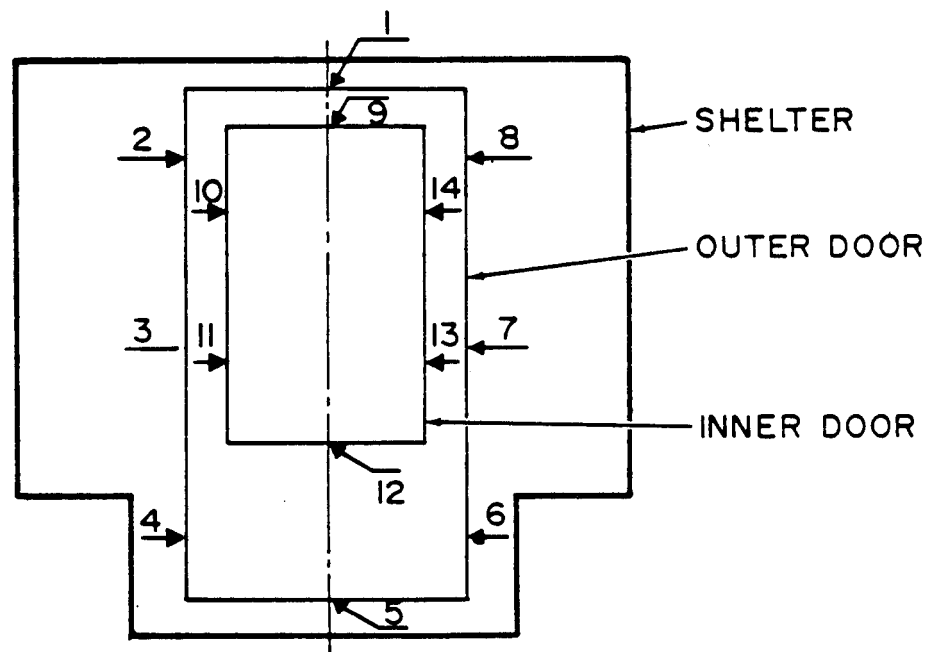

Figure 3-19. Typical Locations for Door Gasket Testing.

3-18. Door Gaskets (cont).

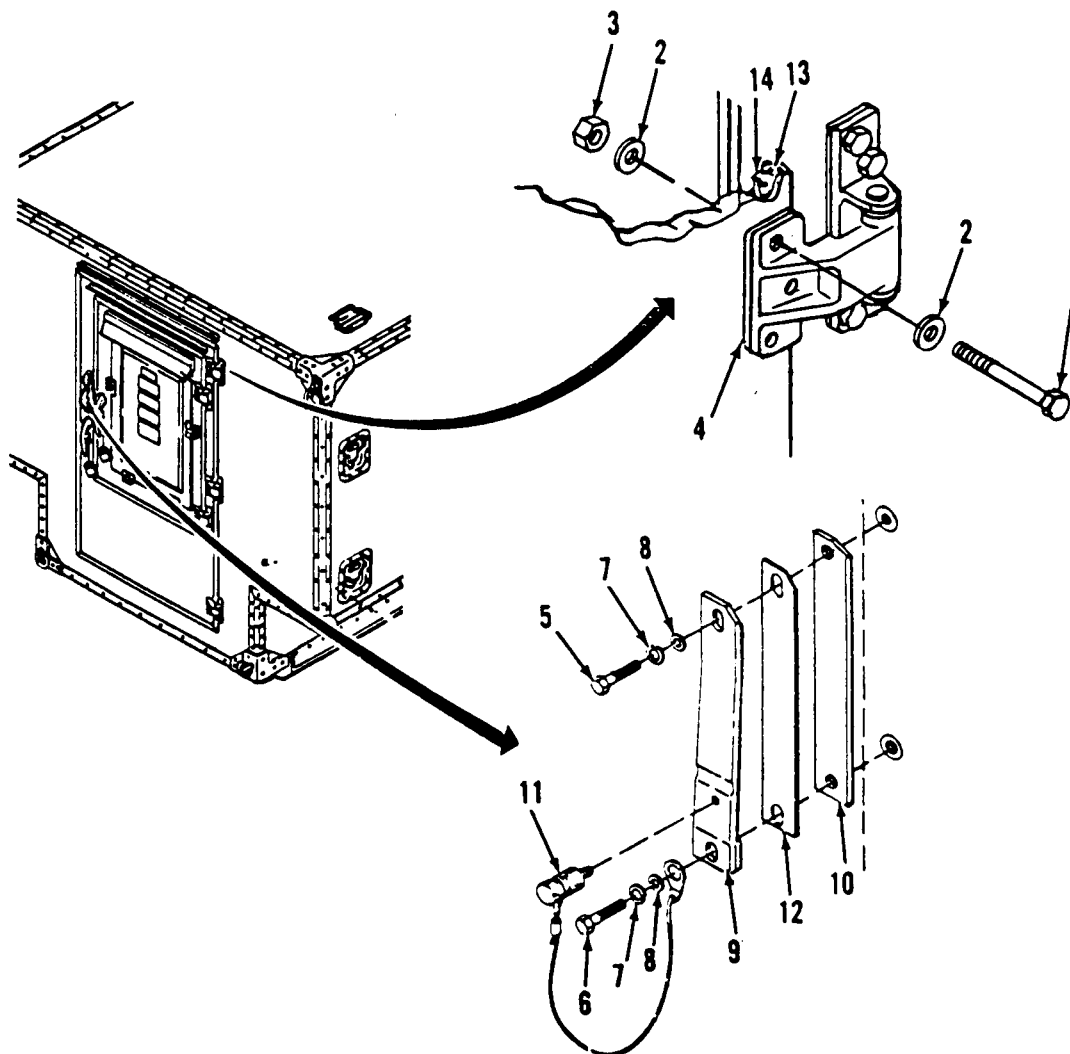

Figure 3-20. Weather Gasket and Seal Pressure Adjustment.

3-19. Door Handle Assembly and Latching Mechanism.

This task covers:

- a. Inspect
- b. Service
- c. Disassemble
- d. Assemble
- e. Repair

INITIAL SETUP

Tools

General Mechanic's Automotive Tool Kit

Materials/Parts

Sealer (Item 28, Appendix D)
 Solid Film Lubricant (Item 22, Appendix D)
 Conductive Compound (Item 33, Appendix D)

NOTE

Except for the length of the latch assembly rods (items 4 and 5, Figure 3-21), the inner door and outer door handle mechanisms are identical. Maintenance procedures are the same for both.

a . Inspect.

- (1) Inspect the door latch assembly for secure mounting and broken or worn parts.
- (2) Inspect for ease of operation.
- (3) Inspect the door handle for tightness and for worn or damaged parts.

b. Service. (Figure 3-21) Service of the door latch assembly consists of lubricating the door handle (8) and latch arm assemblies (10) with lubricant.

c. Disassemble. (Figure 3-21)

NOTE

Disassembly procedures are similar for top and bottom sections of door latch assembly.

- (1) Punch out spring pin (1) and remove flat washer (2).
- (2) Pull pin (3) and push latch rod assemblies (4 and 5) to the side.
- (3) Punch out spring pin (6) attaching the inside handle (7) to outside handle and shaft (8). Remove inside handle (7).

3-19. Door Handle Assembly and Latching Mechanism (cont).

- (4) Punch out grooved pin (9) from underside of latch arm assembly (10) and remove grooved pin (9) to release the latch arm assembly (10). Pull outside handle assembly (8) out of door.
- (5) Remove o-ring (15) from place on outside handle shaft (8).
- (6) Turn the bearing sleeve nut (16) counterclockwise to release the handle shaft sleeve (17) and remove nut (16) and shaft sleeve (17).
- (7) Punch out spring pin (11) and release the roller extension (12) and roller latch (13) from latch arm (14).
- (8) Punch out spring pin (1) and release flat washer (2), pin (18), and latch rod assembly (5).
- (9) Remove nut (19) to release washer (20), spacer (21), latch arm assembly (10), spacers (22, 24, and 25), latch arm detent (23), (at the bottom latch installation only), and bolt (26).
- (10) Remove rivet (27) attaching padlock and chain (28) to panel and remove padlock. (Refer to paragraph 3-9.a for rivet removal instructions.)

d. Assemble.

NOTE

Assembly procedures are similar for top and bottom sections of door latch assembly.

- (1) Place mounting end of padlock and chain (28) over mounting hole and secure with rivet (27). (Refer to paragraph 3-9.a for rivet installation instructions.)
- (2) Place roller extension (12) and roller latch (13) on to latch arm (14) and secure with spring pin (11).

NOTE

When installing the latch arm detent (23) at the bottom section of the assembly, have the latch mechanism fully open so that the raised surface is engaged in the hole of the latch arm assembly (10). Then secure all components by tightening nut (19).

- (3) Apply conductive compound under head of each bolt (26) and place bolt through mounting hole on door.
- (4) Insert spacers (24 and 25), latch arm detent (23), spacer (22), (at top of installation), latch arm assembly (10), spacer (21), and washer (20) on bolt (26), and secure with nut (19).

3-19. Door Handle Assembly and Latching Mechanism (cont).

- (5) Put washer (2) onto pin (18), insert pin (18) through hole on rod latch (4 and 5), and secure with spring pin (1).
- (6) Apply conductive compound under mounting surface of handle shaft sleeve (17) and bearing sleeve nut (16).
- (7) Insert handle shaft sleeve (17) into hole from outside of door panel and secure with bearing sleeve nut (16) from the inside of panel.
- (8) Place o-ring (15) on outside handle shaft (8).
- (9) Insert door handle shaft (8) through handle shaft sleeve (17).
- (10) Insert latch arm (10) onto door handle shaft (8) and secure with spring pin (9).
- (11) Place inside handle (7) onto door shaft and secure with spring pin (6).
- (12) Align holes on latch rod assemblies (4 and 5) with hole on latch arm (10) and insert pin (3). Place washer (2) onto the pin (3) and secure with spring pin (1).
- (13) Apply a continuous bead of sealer around head of bolts (26) and rivet (27).
- (14) Lubricate as required (paragraph 3-1).

e . Repair. Repair of the door latch consists of replacing defective parts.

3-19. Door Handle Assembly and Latching Mechanism (cont).

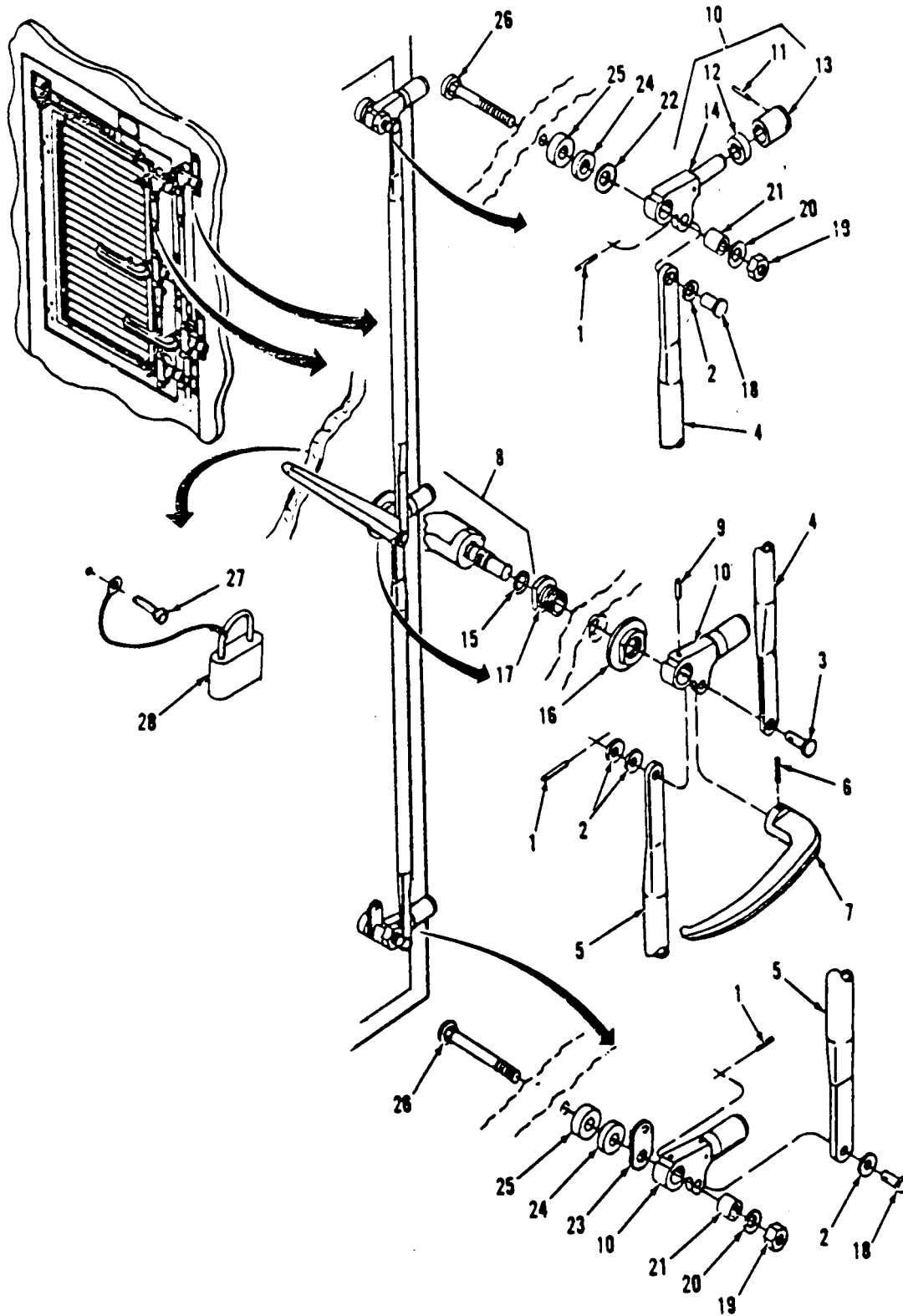

Figure 3-21. Door Handle Assembly and Latching Mechanism Replacement.

3-20. Keeper Assembly.

This task covers: a. Inspect
b. Replace

INITIAL SETUP

<i>Tools</i>	<i>Materials/Parts</i>
General Mechanic's Automotive Tool Kit	None

a. Inspect. (Figure 3-22)

- (1) Inspect for wear and other physical damage.
- (2) Inspect for secure mounting.
- (3) Inspect latch lock assembly (8) for wear or damage.

b. Replace. (Figure 3-22)

NOTE

The middle keeper on each door is tapped for attachment of a latch lock assembly. Maintenance procedures are the same for all keepers and on both the outer door and inner door assemblies.

- (1) Remove and retain hex-head screw (1), lock washer (2), and flat washer (3) from top (upper) hole of keeper assembly (4).
- (2) Remove and retain hex-head screw (5), lock washer (2), and flat washer (3) from bottom (lower) hole of keeper (4) attaching each of the keepers (4) and shim (6) and laminated shim (7) to wall and remove.
- (3) If only latch lock assembly (8) has to be removed, remove and retain hex-head screw (5), lock washer (2), and flat washer (3) attaching tab of latch lock assembly (8) to center keeper at the bottom (lower) hole, and remove latch lock.
- (4) Position laminated shim (7), shim (6), and each keeper (4) in place and secure to shelter wall at top hole using hex-head screw (1), lock washer (2), and flat washer (3).
- (5) Secure keeper (4) to wall at bottom hole using hex-head screw (5), lock washer (2), and flat washer (3).
- (6) If only latch lock assembly (8) has to be installed, position latch lock tab in place over bottom mounting hole of center keeper (4), and secure using hex-head screw (5), lock washer (2), and flat washer (3).

3-20. Keeper Assembly (cont).

- (7) Check latch torque. Latch torque should be 10 foot-pounds without RFI/EMI gasket or 20 foot-pounds with RFI/EMI gasket. Add or subtract shims (6) to achieve proper torque. Use same number and thickness of shims with all three keepers.

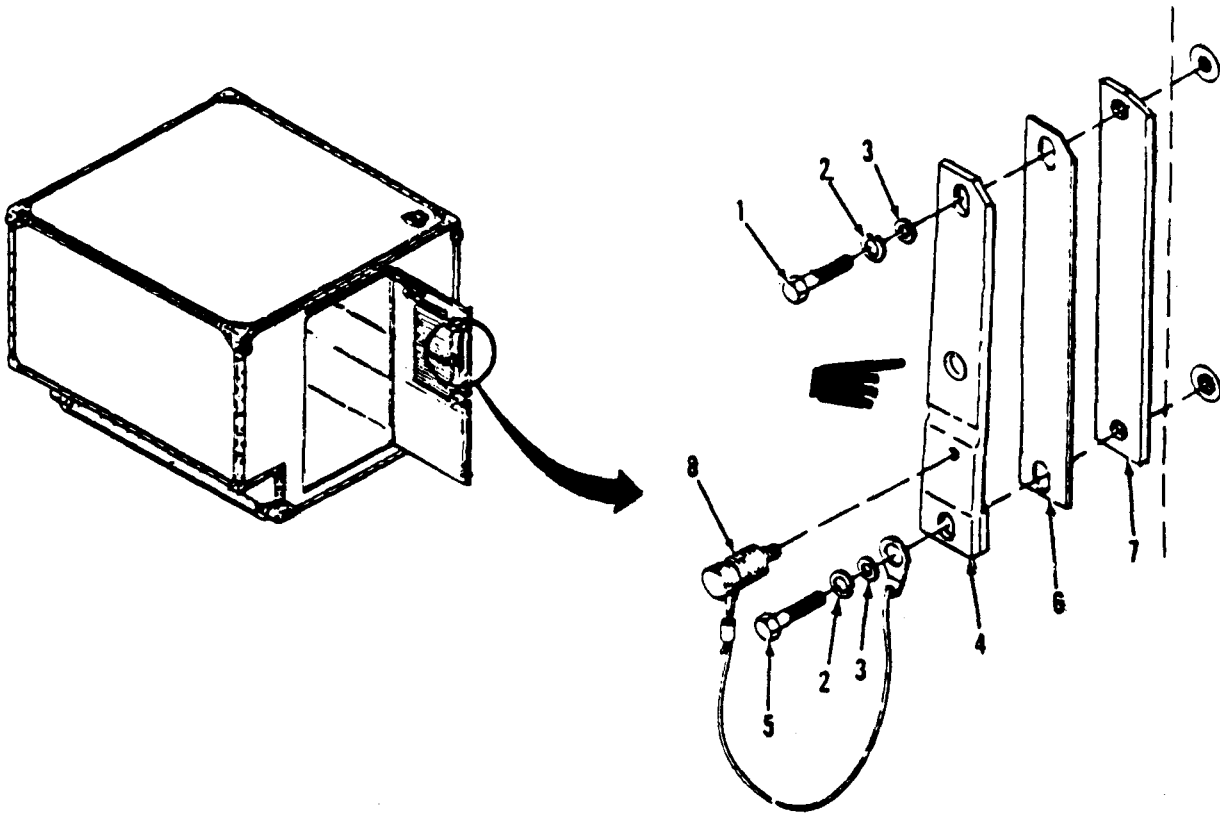

Figure 3-22. Keeper Assembly Replacement.

3-21. Hinge Assembly.

This task covers:

- a. Inspect
- b. Remove
- c. Disassemble
- d. Assemble
- e. Install

INITIAL SETUP*Tools*

General Mechanic's Automotive Tool Kit

*Materials/Parts*Sealer (Item 28, Appendix D)
Conductive Compound (Item 33,
Appendix D)

NOTE

The following repair procedures are the same for the inner door (paragraph 3-23) hinge assembly.

Inspect. (Figure 3-23)

- (1) Inspect for damaged or non-functioning hinge assembly,
- (2) Inspect for missing attaching hardware.

b . Remove.

- (1) Remove and retain three nuts (1) and flat washers (2) attaching each hinge from the inside of door panel.
- (2) Remove and retain three hex head screws (3) and flat washers (2) and remove hinge assembly (4) and laminated shim (5).

c . Disassemble.

- (1) Grind off end of pin (6) and remove pin (6) and flat washer (7).
- (2) Remove hinge leaf (8) and two flat washers (9) from bracket (10).

d . Assemble.

- (1) Position hinge leaf (8) and flat washers (9) in place inside bracket (10) and secure in place with pin (6).
- (2) Place flat washer (7) into pin (6) at opposite end of bracket (10) and peen end of pin (6) over to hold washer (7).

3-21. Hinge Assembly (cont).

e . Install.

- (1) Apply a coat of conductive compound on mounting side of laminated shim (5) and position shim (5) and hinge assembly (4) in place over mounting holes.
- (2) Using three hex head screws (3) and flat washers (2) from the outside of door panel, secure with three flat washers (2) and nuts (1) from inside of panel.
- (3) Apply a continuous bead of sealer around edge of hinge leaf (8) and laminated shim (5) and around head of hex head screws (3).

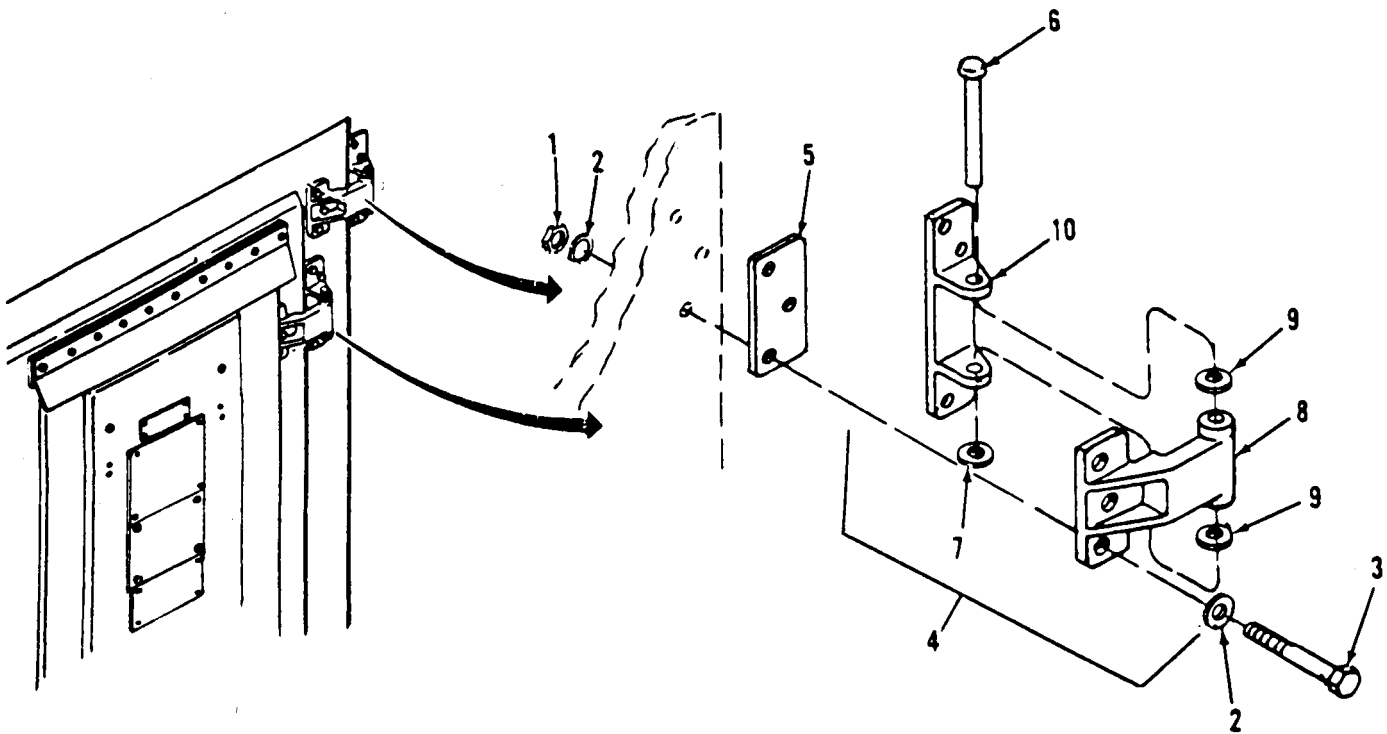

Figure 3-23. Hinge Assembly Replacement.

3-22. Door Hasp.

This task covers: Replace

INITIAL SETUP

Tools

General Mechanic's Automotive Tool Kit

*Materials /Parts*Sealer (Item 28, Appendix D)
Conductive Compound (Item 33, Appendix D)

Replace (Figure 3-24)

- (1) Remove thumb screw (1) and crimp mesh washer (2) from inside of outer door.
- (2) Take hasp (3) off outer door.
- (3) Apply conductive compound on mounting surface of hasp (3).
- (4) Position hasp (3) on outside of outer door under handle (4).
- (5) Install thumb screw (1) with crimp mesh washer (2).
- (6) Apply a continuous bead of sealer around edge of hasp (3).

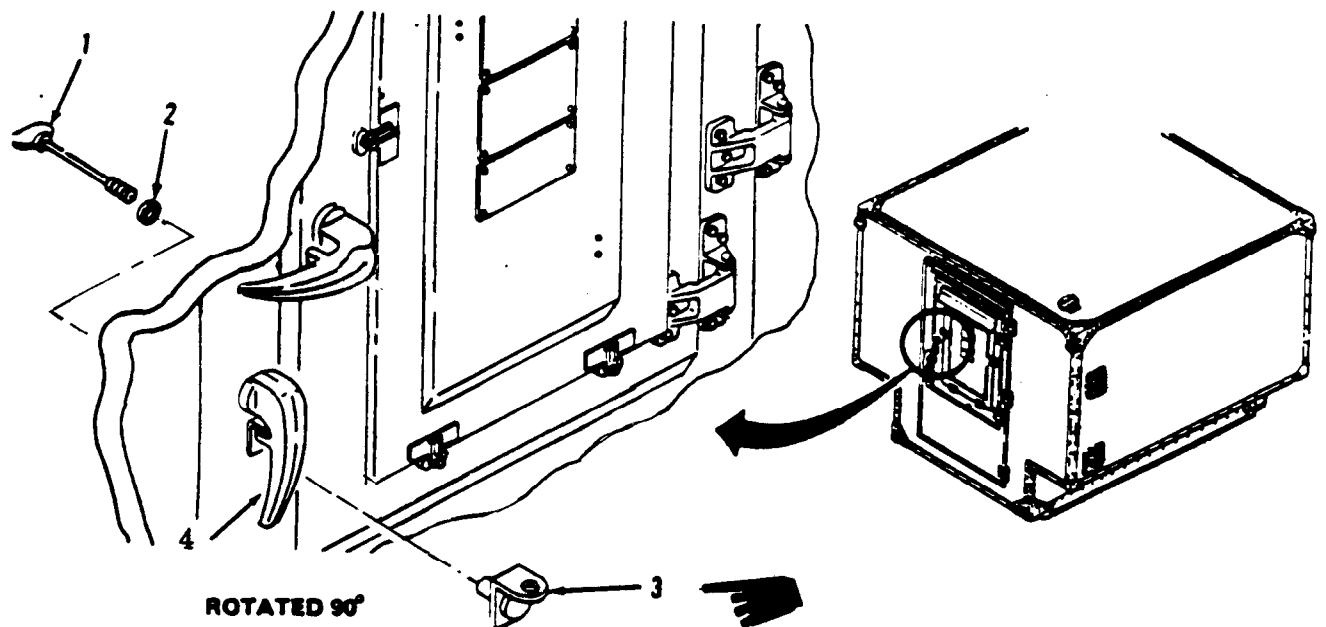
*Figure 3-24. Door Hasp Replacement.*

3-23. Inner Door Assembly.

This task covers:

a. Inspect	e. Test
b. Remove	f. Adjust
c. Repair	
d. Install	

INITIAL SETUP

Tools

General Mechanic's Automotive Tool Kit

Materials/Parts

Sealer (Item 28, Appendix D)
Conductive Compound (Item 33,
Appendix D)

a . Inspect (Figure 3-25)

- (1) Inspect the inner door assembly (6) for external damage.
- (2) Inspect the silicone weather gasket (8) for tightness.
- (3) Inspect the RFI/EMI gasket (12) on a shielded shelter.
- (4) Inspect the door for positive closing and proper operation.
- (5) Inspect the air intake falter (9) for wear and cleanliness.
- (6) Inspect louver assembly (10) and holder assembly (11) for damage and secure mounting.

b . Remove. (Figure 3-25)

- (1) Remove and retain three phillips head screws (1) attaching door stay channel (2) to door panel, and pull channel away from door panel.
- (2) Remove and retain four nuts (5), lock washers (4) and hex-head screws (3) attaching each of the two hinges to outer door panel.
- (3) Remove inner door assembly (6) and two hinge spacers (7).

c . Repair. Inner door assembly repair consists of the following

- (1) Door gasket replacement (paragraph 3-18).
- (2) Door handle assembly and latching mechanism replacement (paragraph 3-19).
- (3) Keeper assembly replacement (paragraph 3-20).
- (4) Hinge assembly replacement (paragraph 3-21).

3-23. Inner Door Assembly (cont).

- (5) Louver assembly, holder assembly, and RFI/EMI filter replacement (paragraph 3-24).
- (6) Directional vane assembly and air intake filter replacement (paragraph 3-26).
- (7) Louver cover assembly latches replacement (paragraph 3-26).

d. Install.

- (1) Coat both sides of each hinge spacer (7) with conductive compound.
- (2) Position each spacer (7) and inner door panel (6) in place and secure to outer door panel with four hex-head screws (3), lock washers (4), and nuts (5).
- (3) Position door stay assembly channel (2) in place and secure to inner door panel (6) with three phillips head screws (1).
- (4) Apply a continuous bead of sealer around spacer (7) and hinge bracket, and around head of screws (5).

Test. See paragraph 3-18b.

Adjust. See paragraph 3-18c.

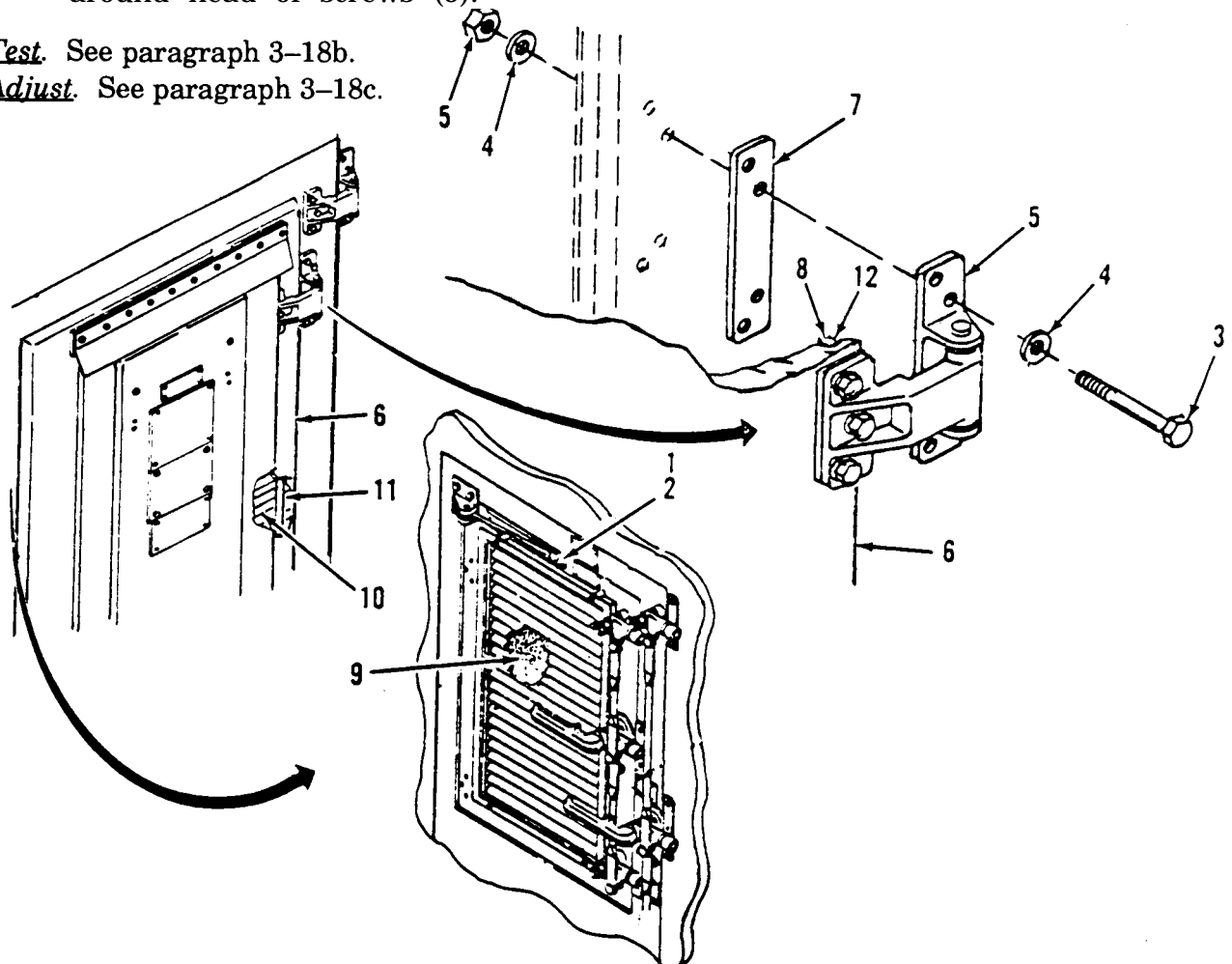

Figure 3-25. Inner Door Assembly Replacement.

3-24. Louver Assembly, Holder Assembly and RFI/EMI Filter.

This task covers

- a. Inspect
- b. Remove
- c. Repair
- d. Install

INITIAL SETUP

Tools

General Mechanic's Automotive Tool Kit

Materials/Parts

Sealer (Item 28, Appendix D)
Sealer, Silicone (Item 26, Appendix D)

NOTE

RFI/EMI filters on inner door assembly are on shielded shelters only.

a . Inspect. (Figure 3-26)

- (1) Inspect holder assembly (4) for secure mounting or damaged parts.
- (2) Inspect louver assembly (12) for external damage.
- (3) Inspect frame (18) and frame assembly (11) for secure mounting.

b . Remove. (Figure 3-26)

- (1) Prop louver cover assembly open.
- (2) Remove and retain four phillips head screws (1), nuts (2), and lock washers (3), and remove holder assembly (4) from frame assembly (11).
- (3) Punch out groove pin (5) to remove holder (6) from bracket assemblies (7).
- (4) Remove and retain 31 phillips head screws (8), nuts (9), and lock washers (10) attaching frame assembly (11) to inner door panel. While supporting louver assembly (12) on bottom with one hand, remove gasket (13) and frame assembly (11) from inner door assembly (14).
- (5) Slide louver assembly (12) and gasket (13) out of frame assembly (11).
- (6) Remove and retain seven phillips head screws (15), nuts (16), and lock washers (17) attaching frame (18) to inner door assembly (14). Remove frame (18), shield (19), and RFI/EMI filter (20).

c . Repair. Repair consists of replacing missing, damaged or defective parts.

3-24. Louver Assembly, Holder Assembly and RFI/EMI Filter (cont).

d. Install. (Figure 3-26)

- (1) Apply sealer to both ends of top flange of shield (19).
- (2) Position RFI/EMI filter (20), shield (19), and frame (18) in place into inner door assembly (14), and secure with seven phillips head screws (15), nuts (16), and lock washers (17).
- (3) Apply silicone sealer on mounting surface of gasket (13) and insert gasket (13) and louver assembly (12) into frame assembly (11).
- (4) Position frame assembly (11) in place against RFI/EMI filter (20) and secure with 31 phillips head screws (8), nuts (9), and lock washers (10).
- (5) Position each end of holder (6) into bracket assemblies (7) and secure with groove pins (5).
- (6) Position holder assembly (4) in place over frame assembly (11) and secure with four phillips head screws (1), nuts (2), and lock washers (3).
- (7) Apply a continuous bead of sealer around mounting edges of frame (18) and frame assembly (11).

3-24. Louver Assembly, Holder Assembly and RFI/EMI Filter (cont).

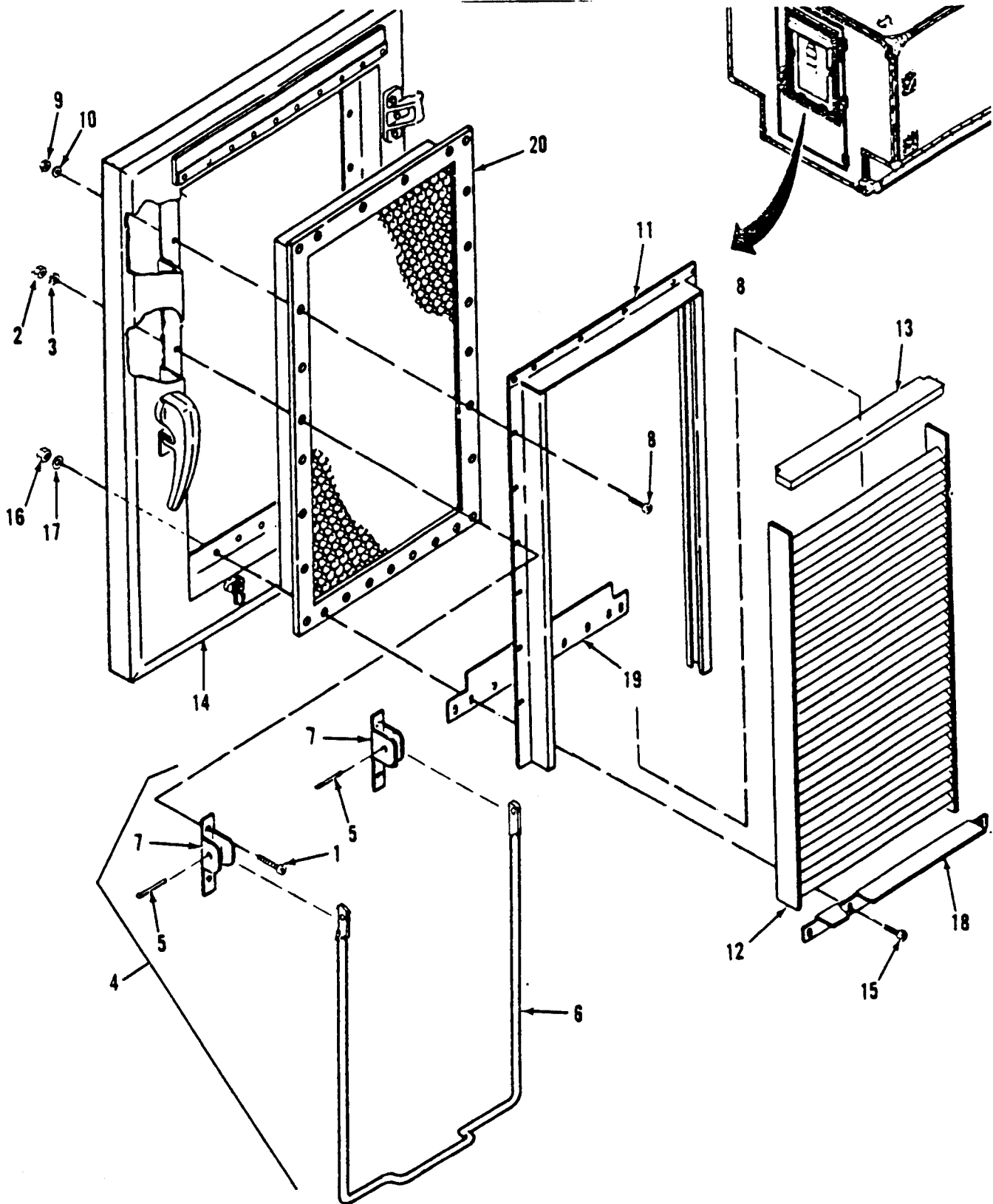

Figure 3-26. Louver Assembly, Holder Assembly, and RFI/EMI Filter Replacement.

3-25. Directional Vane Assembly and Air Intake Filter.

This task covers: a. Inspect
 b. Replace

INITIAL SETUP*Tools**Materials/Parts*

General Mechanic's Automotive Tool Kit

Sealer (Item 28, Appendix D)

a. Inspect.

- (1) Inspect for damaged directional vane assembly.
- (2) Inspect for loose or missing attaching hardware.

b. Replace. (Figure 3-27)

- (1) Remove and retain four phillips head screws (1) and lock washers (2) and take directional vane assembly (3) off inside of inner door assembly (4). Remove air intake falter (5).
- (2) Inspect condition of rivnuts (6) and replace if necessary (paragraph 3-9. b). Replacement rivnuts must have same inside diameter and thread size as rivnut removed. Dip new rivnuts in sealer prior to installation.
- (3) Position air intake falter (5) in recess on inside of inner door assembly (4).
- (4) Position directional vane assembly (3) on inner door assembly (4) over falter (5). Make sure vanes are aiming up toward interior of shelter, as shown in figure 3-27. Dip four phillips head screws (1) in sealer and install with four lock washers (2).

3-25. Directional Vane Assembly and Air Intake Filter (cont).

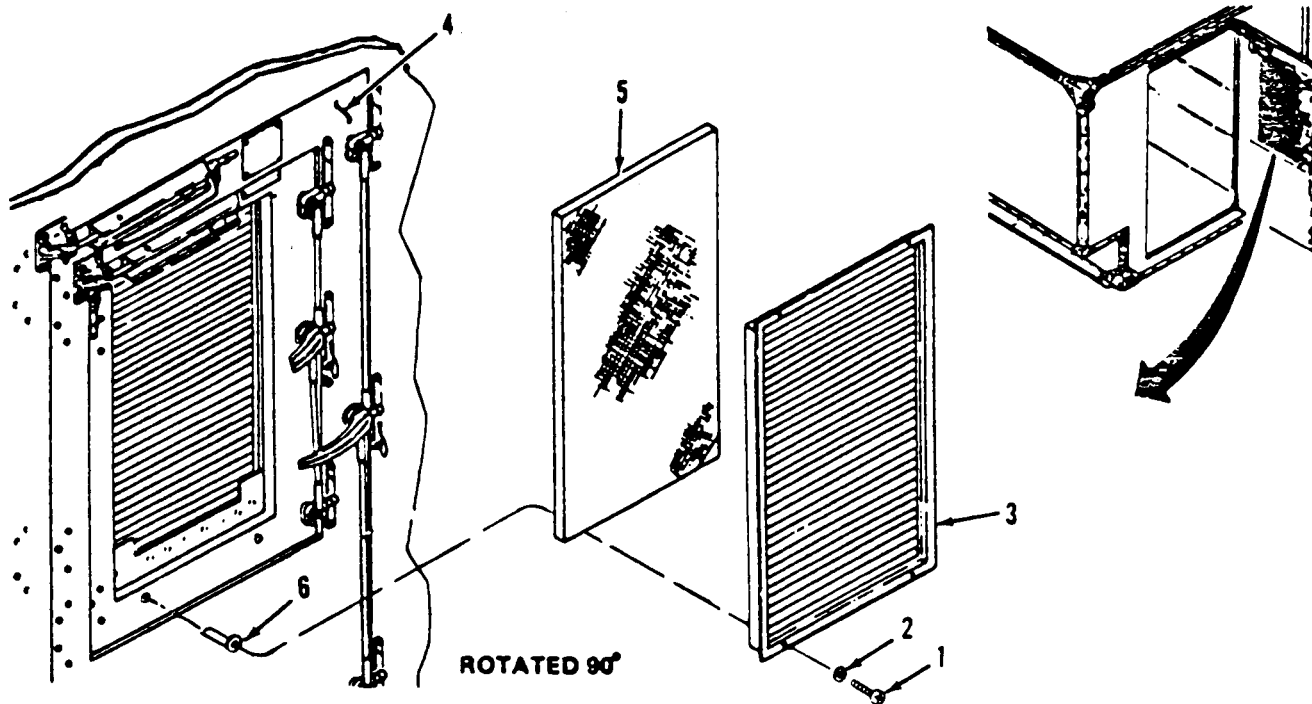

Figure 3-27. Directional Vane Assembly and Air Intake Filter Replacement.

3-26. Louver Cover Assembly Latches.

This task covers: a. Inspect
 b. Replace

INITIAL SETUP*Tools**Materials/Parts*

General Mechanic's Automotive Tool Kit

Sealer (Item 28, Appendix D)

a. Inspect. (Figure 3-28)

- (1) Inspect latch (3) for wear or damage.
- (2) Inspect stud plate assembly (5) for damage and secure mounting.
- (3) Check for loose or missing hardware.

b. Replace. (Figure 3-28)

- (1) Remove and retain a nut (1), flat washer (2), latch (3), and flat washer (4) from stud plate assembly (5).
- (2) Remove and retain two flat head screws (6) attaching stud plate assembly (5) to inner door panel (7) and remove the stud plate (5) and spacer (8).
- (3) Inspect condition of rivnuts (9) and replace if necessary (paragraph 3-9.b).
- (4) Position spacer (8) and stud plate assembly (5) in place, dip the two mounting screws (6) in sealer, and secure stud plate (5) and spacer (8) to inner door panel (7).
- (5) Slide flat washer (4), latch (3), and flat washer (2) onto stud and secure with nut (1).
- (6) Apply a continuous bead of sealer around spacer (8).

3-26. Louver Cover Assembly Latches (cont).

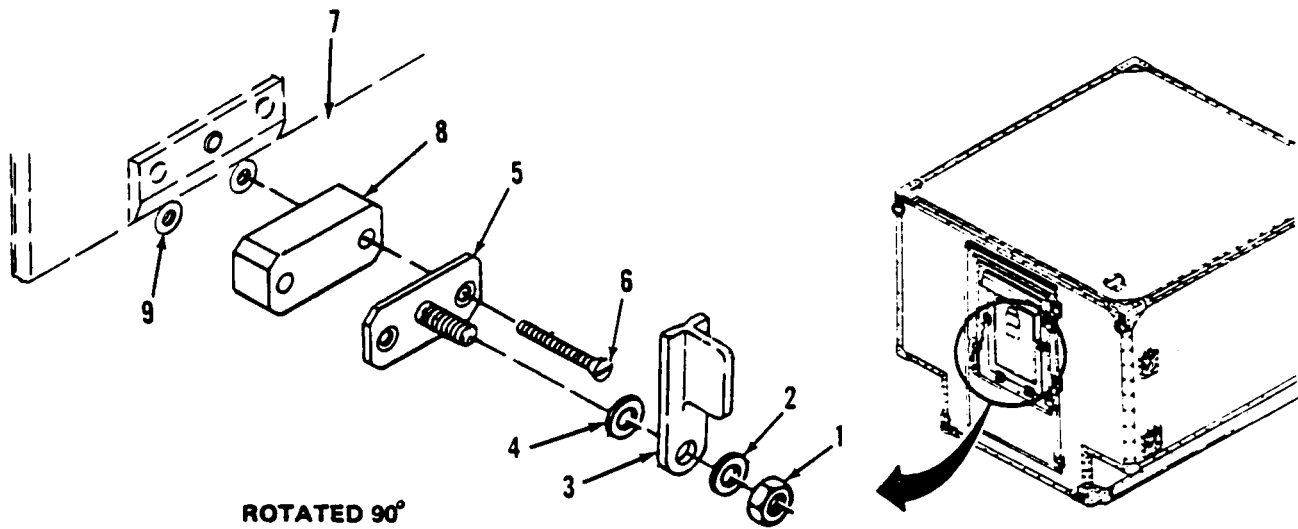

Figure 3-28. Louver Cover Assembly Latch Replacement.

3-27. Shield (Rain Flap).

This task covers: Replace

INITIAL SETUP
Tools

General Mechanic's Automotive Tool Kit

Materials/Parts

Sealer (Item 28, Appendix D)
 Rubber (Item 34, Appendix D)

Replace (Figure 3-29)

- (1) Remove and retain ten phillips head screws (1) and lock washers (2) attaching retainer (3) and shield (4) to spacer (5) and remove retainer (3) and shield (4).
- (2) Cut a new shield (4), using old shield as a template.
- (3) Using retainer (3) as a template, punch ten mounting holes in upper edge of shield (4).

NOTE

Dip mounting screws (1) in sealer prior to installation.

- (4) Position shield (4) and retainer (3) on spacer (5) so that mounting holes line up. Secure with ten phillips head screws (1) and lock washers (2).

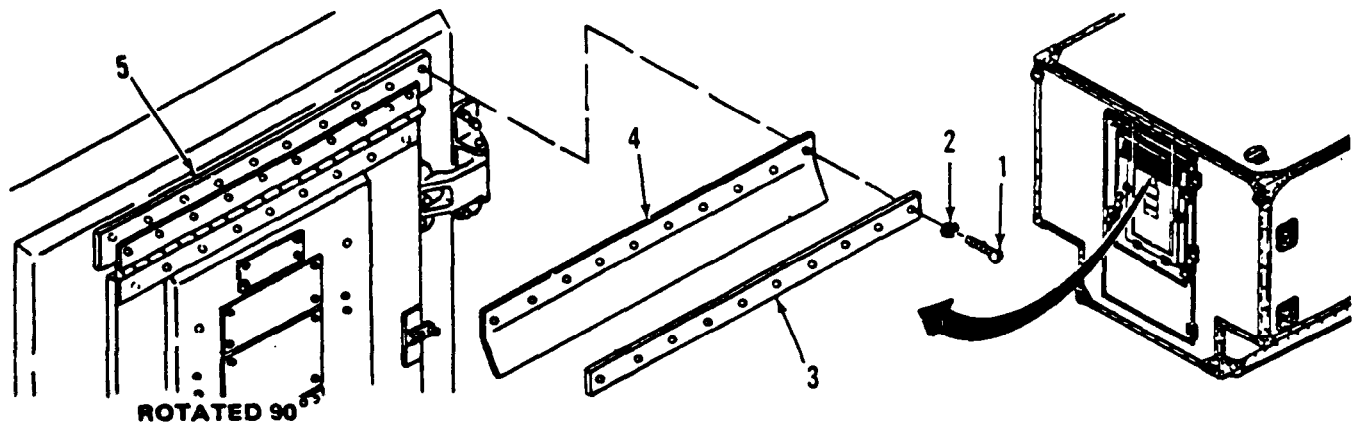

Figure 3-30. Shield (Rain Flap) Replacement.

3-28. Louver Cover Assembly.

- This task covers
- a. Inspect
 - b. Remove
 - c. Repair
 - d. Install
-

INITIAL SETUP

Tools

General Mechanic's Automotive Tool Kit

Materials/Parts

Sealer (Item 28, Appendix D)
Sealer, Silicone. (Item 26, Appendix D)
Gasket, Silicone (Item 27, Appendix D)

a. Inspect. (Figure 3-30)

- (1) Inspect the louver cover assembly (3) for external damage.
- (2) Inspect the silicone weather gasket (6) located on the track on the inside periphery of the cover.
- (3) Inspect the two clips (7) and four clips (8) for wear and secure mounting.
- (4) Inspect the five data plates for legibility and secure mounting.

b. Remove. (Figure 3-30)

- (1) Remove and retain ten phillips head screws (1) and lock washers (2) attaching louver cover assembly (3) to inner door assembly (4).
- (2) Turn four latches, attaching the lower cover assembly (3) to inner door assembly, off from louver cover and remove cover (3) and cover shim (5).
- (3) Remove silicone weather gasket (6) from inside of louver cover.

c. Repair. (Figure 3-30) Repair of the louver cover assembly consists of the following

- (1) Data plate replacement (paragraph 3-29).
- (2) Strike replacement (paragraph 3-30).
- (3) Clip replacement (paragraph 3-31).
- (4) Hinge replacement. If the hinge is damaged but the rest of the cover assembly is intact, proceed as follows

- (a) Drill out nine rivets (9) attaching hinge (10) to panel. (Refer to paragraph 3-9.a for rivet removal instructions.)

3-28. Louver Cover Assembly.

(b) Position new hinge (10) in place on cover assembly (3) and secure with nine rivets (9). (Refer to paragraph 3-9.a for rivet installation instructions.)

d. Install. (Figure 3-30)

- (1) Clean adhesive residue from gasket track in panel cover, and apply RTV 138 silicone sealer in track groove.

CAUTION

Allow at least 30 minutes cure time for the silicone sealer to adhere before using louver cover.

- (2) Snap new silicone gasket (6) in track on louver cover panel.
- (3) Position louver cover assembly (3) in place on inner door assembly (4) and turn four latches onto louver cover to hold cover in place.
- (4) Dip ten phillips head screws (1) in sealer, position cover shim (5) in place behind cover hinge, and secure with screws (1) and lock washers (2).
- (5) Apply a continuous bead of sealer on the top mounting edge of cover shim (5) and cover hinge.

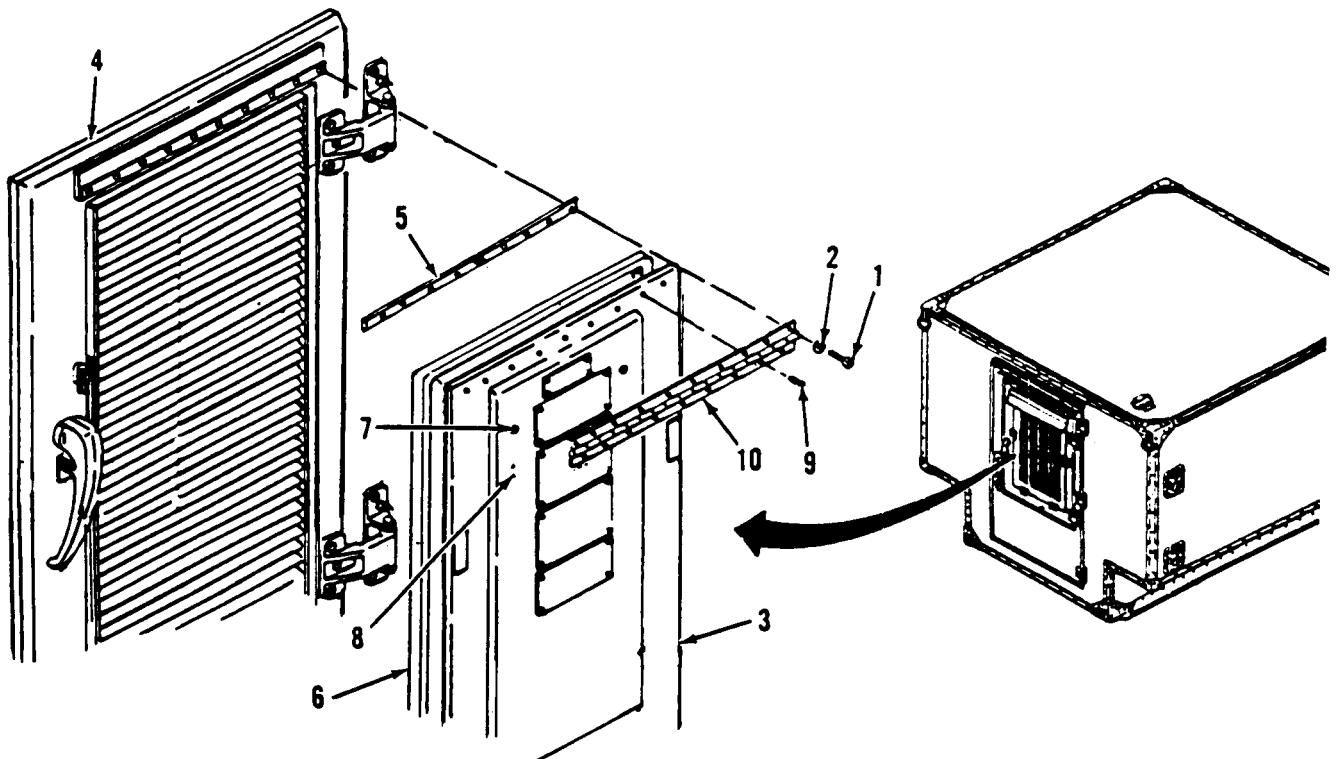

Figure 3-30. Louver Cover Assembly Replacement.

3-29. Data Plates.

This task covers: Repair

INITIAL SETUP

Tools

General Mechanic's Automotive Tool Kit
Blind Riveter

Materials/Parts

Sealer (Item 28, Appendix D)

Repair. (Figure 3-31) Repair of the data plates consists of replacement of the missing, damaged, or defective parts, as necessary, according to the following procedure:

- (1) Remove four rivnuts (1) attaching the aircraft loading data date (2) to louver cover assembly panel (3). (Refer to paragraph 3-9.b for rivnut removal instructions.)
- (2) Place the aircraft loading data plate (2) in place and secure to door with four rivnuts (1). (Refer to paragraph 3-9.b for rivnut installation instructions.)

NOTE

The following procedures are similar for all other data plates in this shelter.

- (3) Remove four blind rivets (4) securing data plate (5) to louver cover assembly panel (3) and remove plate. (Refer to paragraph 3-9.a. for rivet removal instructions.)
- (4) Place data date (5) in place on door and secure with four blind rivets (4). (Refer to paragraph 3-9.a. for rivet installation instructions.)

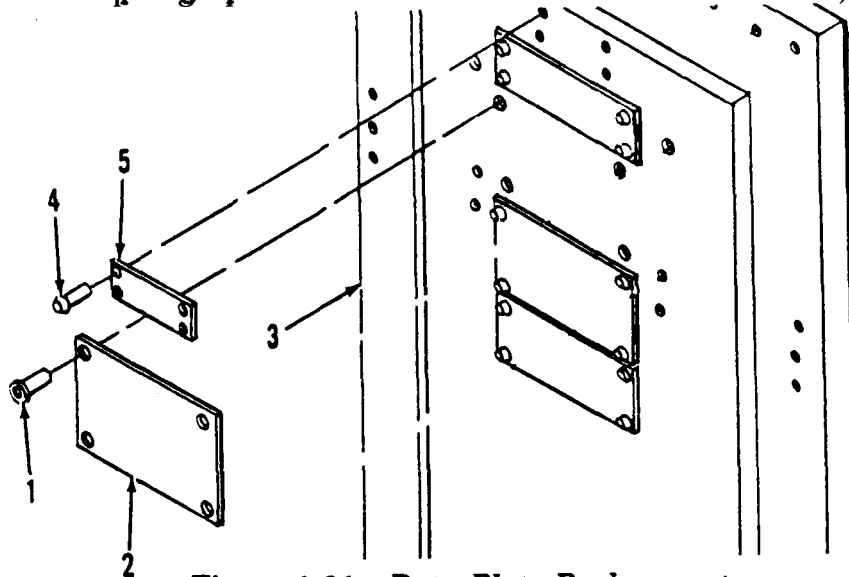

Figure 3-31. Data Plate Replacement.

3-30. Louver Cover Assembly Strikes.

This task covers: Replace

INITIAL SETUP*Tools*

General Mechanic's Automotive Tool Kit
Blind Riveter

Materials/Parts

Sealer (Item 28, Appendix D)

Replace. (Figure 3-32)

- (1) Remove two countersunk head rivets (1) and one dome head rivet (2) attaching each strike (3) to louver cover, and remove strike (3). (Refer to paragraph 3-9.a for rivet removal instructions.)
- (2) Position strike (3) on louver cover, Dip mounting rivets in sealer.
- (3) Secure strike (3) with two countersunk head rivets (1) and one dome head rivet (2). (Refer to paragraph 3-9.a for rivet installation instructions.)

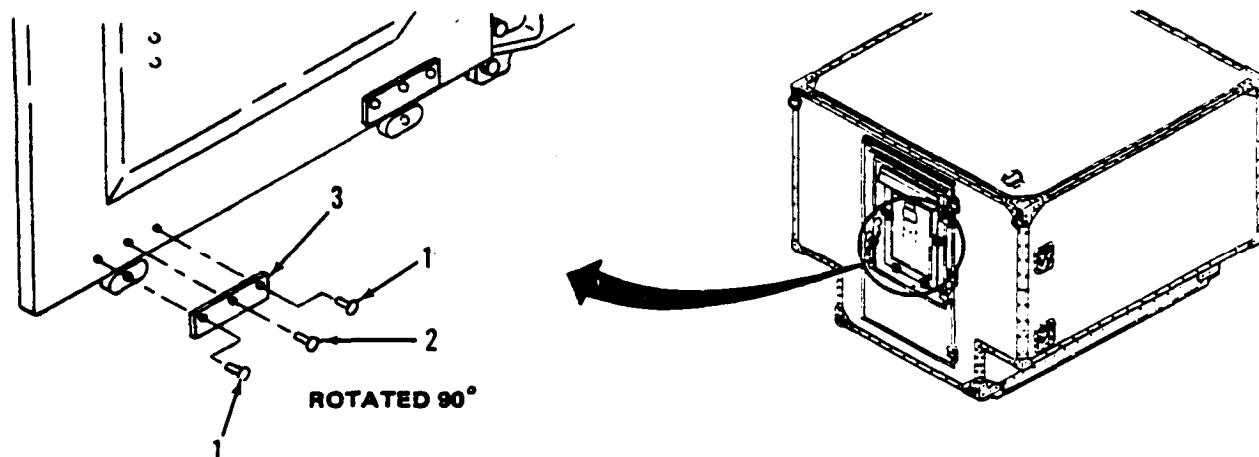

Figure 3-32. Louver Cover Assembly Strike Replacement.

3-31. Louver Cover Assembly Clips.

This task covers: Replace

INITIAL SETUP

Tools

General Mechanic's Automotive Tool Kit
Blind Riveter

Materials/Parts

Sealer (Item 28, Appendix D)

Replace. (Figure 3-33)

- (1) Remove and retain screw (1), flat washer (2), and nut (3) attaching each of the two clips (4) to louver cover, and remove clip (4) and flat washer (2).
- (2) Drill out two rivets (5) and remove clip (6) off louver cover. (Refer to paragraph 3-9.a for rivet removal instructions.)
- (3) Position each clip (6) on inside of louver cover and secure with two rivets (6) dipped in sealer prior to installation. (Refer to paragraph 3-9.a for rivet installation instructions.) When installed, rivet heads should be on inside of louver cover.
- (4) Position one flat washer (2) and clip (4) on inside of louver cover and secure with screw (1), flat washer (2), and nut (3). Apply sealer around head of screws (1).

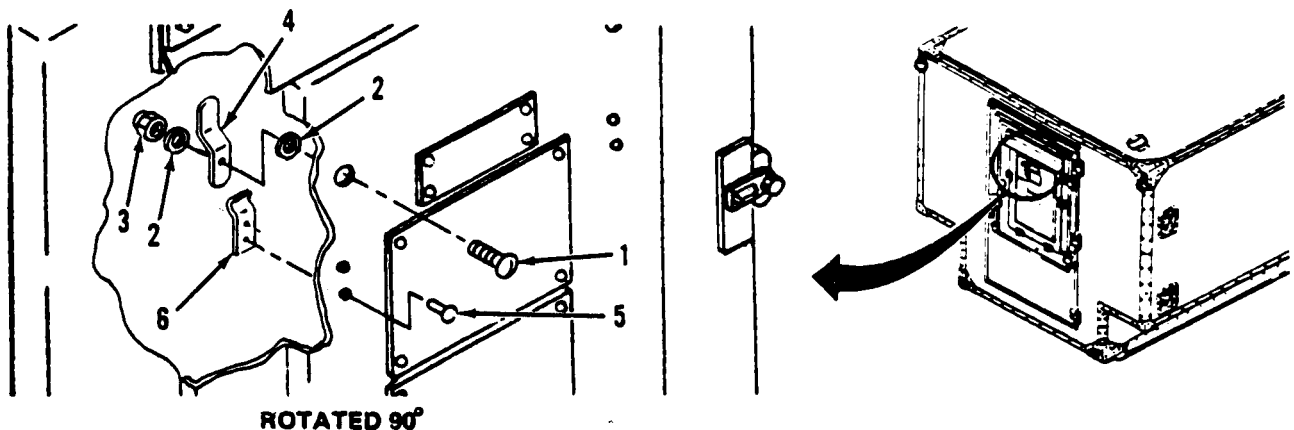

Figure 3-33. Louver Cover Assembly Clip Replacement.

3-32. Door Stay Assembly.

This task covers:

a. Inspect	d. Repair
b. Remove	e. Assemble
c. Disassemble	f. Install

INITIAL SETUP

Tools

Materials/Parts

General Mechanic's Automotive Tool Kit

Sealer (Item 28, Appendix D)

a. Inspect. (Figure 3-34)

- (1) Inspect for missing or damage hardware.
- (2) Inspect for wear, dents, or other damage.
- (3) Inspect that rod (13) moves freely.
- (4) Inspect for secured or damaged detent pin (2).

b. Remove. (Figure 3-34)

- (1) Drill out rivet (1) attaching lanyard tab of detent pin (2) and remove detent pin.
- (2) Drill out two rivets (3) attaching spring tension clip (4) and remove clip (4).
- (3) Push door open and remove and retain three phillips head screws (5) attaching door stay channel (6) to door panel (outer or inner door).
- (4) Remove and retain three hex-head screws (7) and lock washers (8) attaching door stay bracket (9) to panel (shelter or inner door), and remove door stay assembly (10).
- (5) Inspect condition of rivnuts (11 and 12) and replace if necessary (paragraph 3-9.b).

c. Disassemble. (Figure 3-34)

- (1) Push channel assembly (6) out of door stay rod (13).
- (2) Grind off end of pin (14) and remove flat washer (15).
- (3) Remove pin (14) to release door stay rod (13) and two flat washers (16) from bracket (9).

d. Repair. Repair of the door stay assembly consists of replacement of the damaged or malfunctioning component.

3-32. Door Stay Assembly (cont).

e. Assemble. (Figure 3-34)

- (1) Position two flat washers (16) and door stay rod (13) in place inside bracket (9) end secure in place with pin (14).
- (2) Push flat washer (15) in place from bottom of pin (14), and peen end of pin (14) over to hold washer (15).
- (3) Slide rod end (13) into channel assembly (6).

f. Install. (Figure 3-34)

- (1) Position channel assembly (6) on door panel (outer or inner door) and secure to panel with three phillips head screws (5) after dipping screws in sealer.
- (2) Position bracket (9) in place on panel (shelter or outer door panel) and secure with three hex-head screws (7) dipped in sealer, and three lock washers (8).
- (3) Position spring tension clip (4) and secure to panel with two rivets (3) dipped in
- (4) With a rivet (1) dipped in sealer, attach lanyard tab of detent pin (2) to door panel (outer or inner door panel).

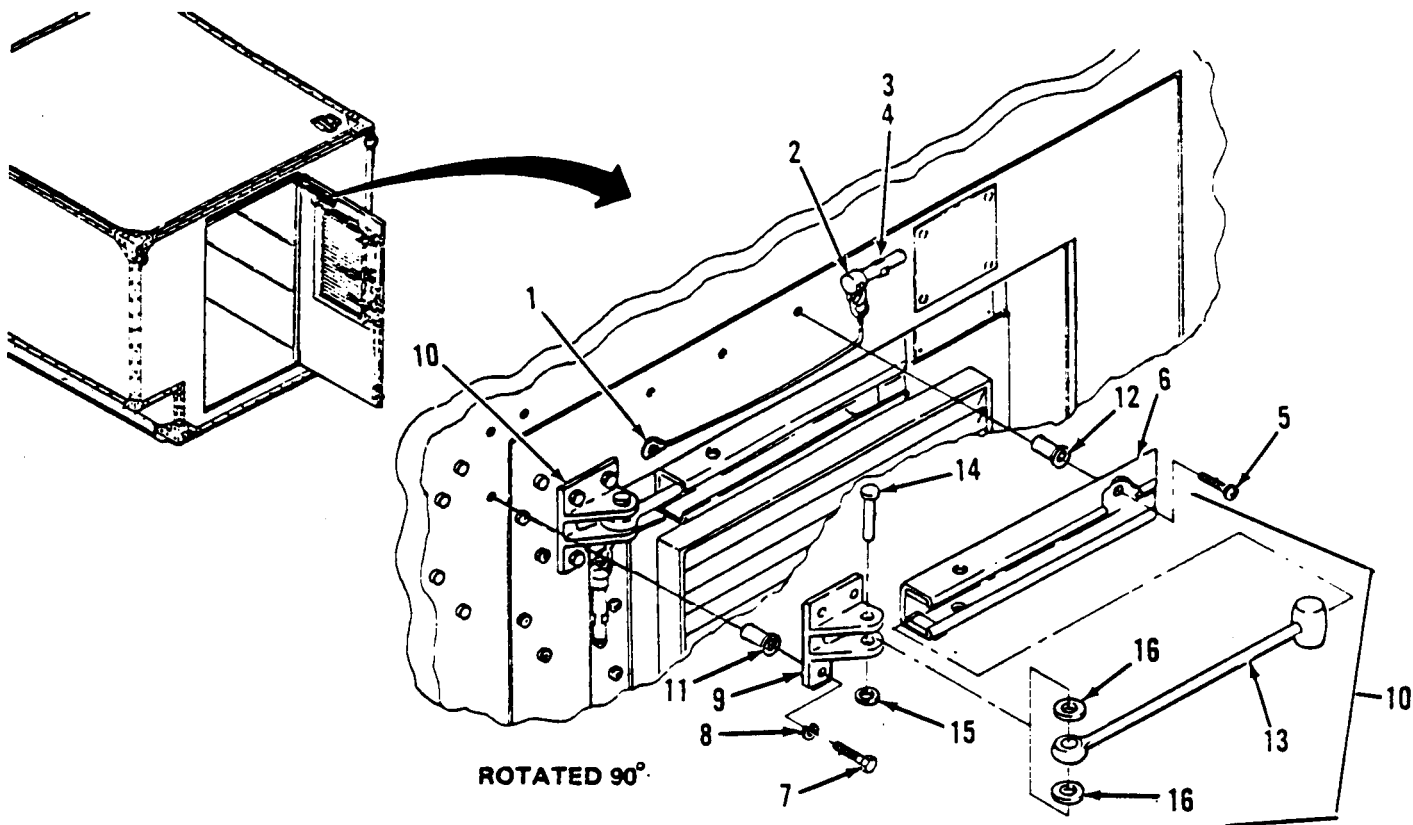

Figure 3-34. Door Stay Assembly Repair and Replacement.

3-33. Skid Assembly.

This task covers	a. Inspect b. Remove c. Disassemble	d. Repair e. Assemble f. Install
------------------	---	--

INITIAL SETUP*Tools**Materials/Parts*

General Mechanic's Automotive Tool Kit

Sealer (Item 28, Appendix D)

a. Inspect.
WARNING

Prior to attempting to perform maintenance on the skids, ensure that shelter is supported properly to prevent injury to personnel.

- (1) Inspect for secure mounting and dents.
- (2) Inspect for damage to skirts (1, Figure 3-36).

CAUTION

The shelter should be raised and supports placed on the bottom of the front and rear panels between skids. The skids should be approximately one foot above the ground.

NOTE

Although the skids may be damaged with dents, they can be used again if the skirts and spring are replaced.

b. Remove. (Figure 3-35)

- (1) Remove and retain three hex-head bolts (1) attaching each end of skid assembly (2) to underside of towing brackets, and remove plates (3).
- (2) Remove and retain 24 phillips head screws (4) attaching skid (2) to side panel of shelter.
- (3) Remove and retain 1x2 phillips head screws (5) attaching skid to underside of shelter floor panel, and remove skid (2) and two rubber blocks (6).
- (4) Inspect condition of rivnuts (7 and 8) and replace if necessary (paragraph 3-9.b).

3-33. Skid Assembly (cont).

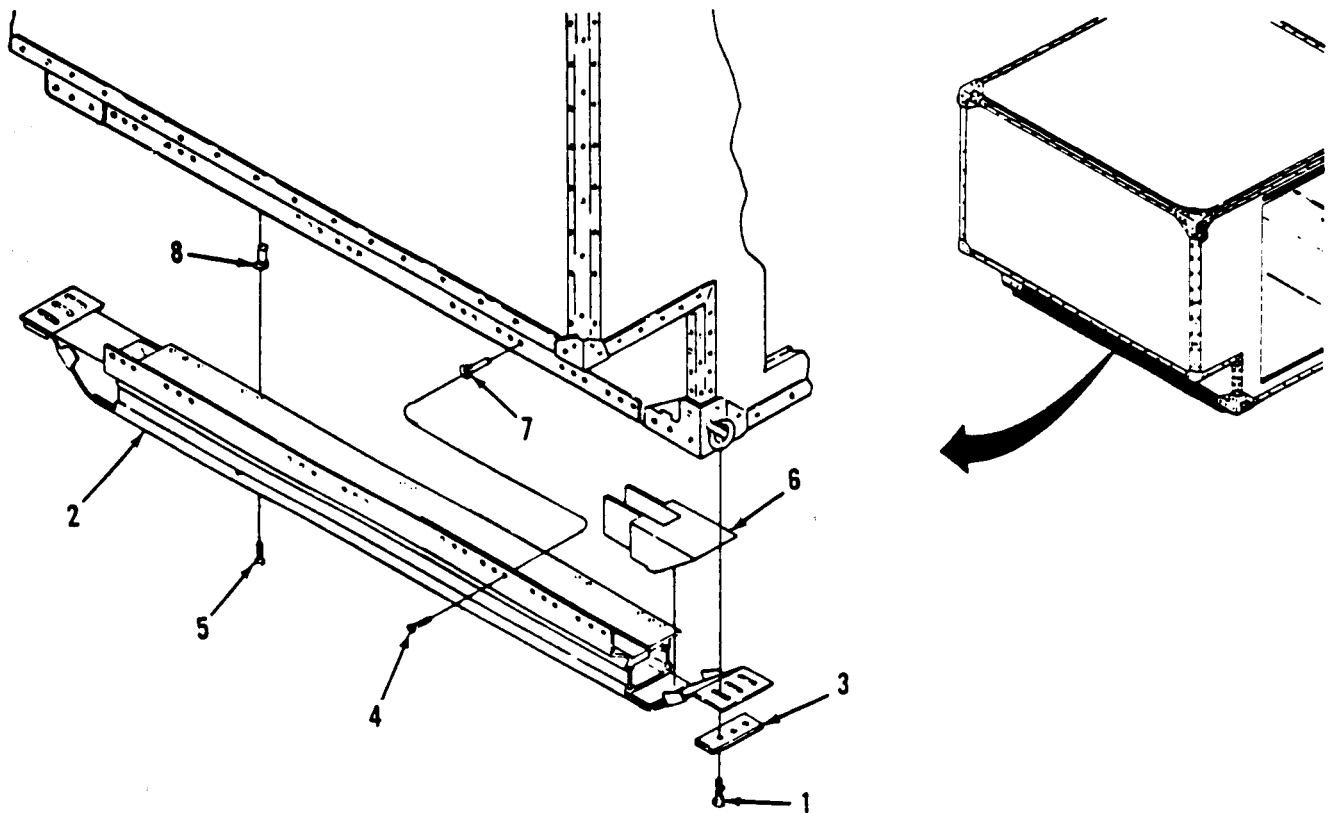

Figure 3-35. Skid Assembly Replacement.

c. *Disassemble.* (Figure 3-36)

- (1) Pull skirt (1) out of mounting grooves of upper plate assembly (2) and nose plate assembly (3).
- (2) Drill out four rivets (4) and two rivets (5) attaching spring (6) to skid plate (7), and remove spring (6) and spacer (8).
- (3) Drill out 16 rivets (9) attaching each noseplate (10 and 11) to plate (12) and shoe (13).
- (4) Drill out two rivets (14) attaching each plate (12) to shoe (13) and remove plates (12) from shoe (13).

d. *Repair.* Repair of the skid assembly consists of replacement of the damaged skirts, spring, or noseplate assembly.

e. *Assemble.* (Figure 3-36)

- (1) Position each plate (12) in place on shoe (13) and secure with two rivets (14). (Refer to paragraph 3-9.a for rivet installation instructions.)

3-33. Skid Assembly (cont).

- (2) Position each noseplate (10 and 11) in place over each plate (12) and secure to plate (12) and shoe (13) with 16 rivets (9).
 - (3) Place spring (6) under skid plate (7) and secure with four rivets (4) and two rivets (5).
 - (4) Push each skirt (1) in mounting grooves noseplate assembly (3). Align grooves of upper plate assembly (2) with top flange of skirts (1) and push in place.
- d. Install. (Figure 3-35)

NOTE

Coat the shafts and undersides of heads of screws and bolts completely with sealer before installing.

- (1) Position each skid assembly (2) and two rubber blocks (6) in place under shelter and secure to underside of floor panel with 12 phillips head screws (5).
- (2) Secure skid assembly (2) to side panel of shelter with 24 phillips head screws (4).
- (3) Position each plate (3) in place and secure with three hex-head screws (1).
- (4) Apply a continuous bead of sealer around all mating edges of skid assembly and shelter panels.

3-33. Skid Assembly (cont).

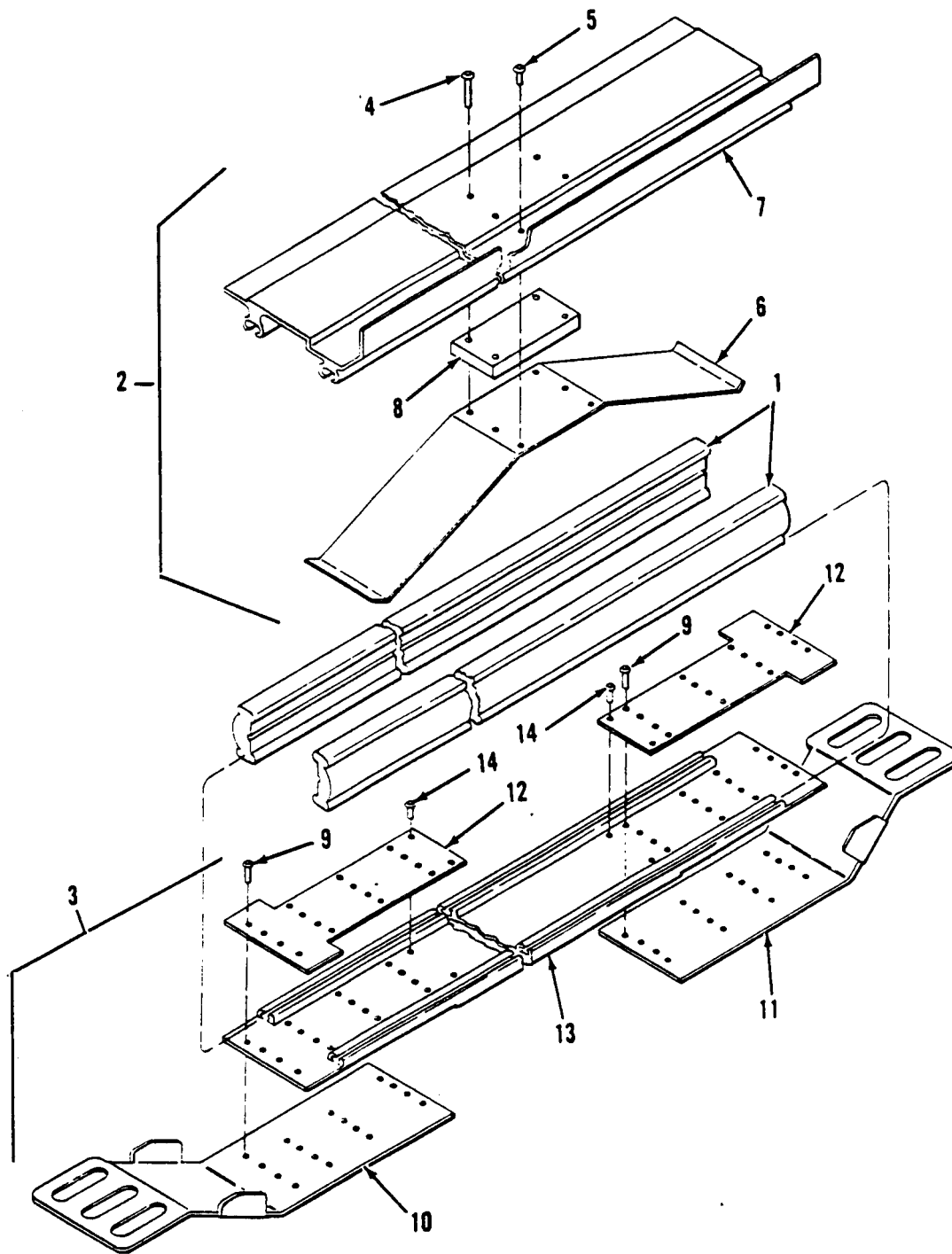

Figure 3-36. Skid Assembly Repair.

3-34. Towing Bracket Assembly.

This task covers a. Inspect
 b. Repair

INITIAL SETUP*Tools***General Mechanic's Automotive Tool Kit**

a. Inspect. (Figure 3-37)

- (1) Inspect for free movement and secure mounting.
- (2) Inspect for cracks or other external damage.

b. Repair. (Figure 3-37)

- (1) Remove bolt (1) and nut (2) attaching towing eye (3) to bracket (4) and remove from bracket.
- (2) Align mounting holes of new towing eye (3) with holes on bracket (4) and secure to bracket with bolt (1) and nut (2).

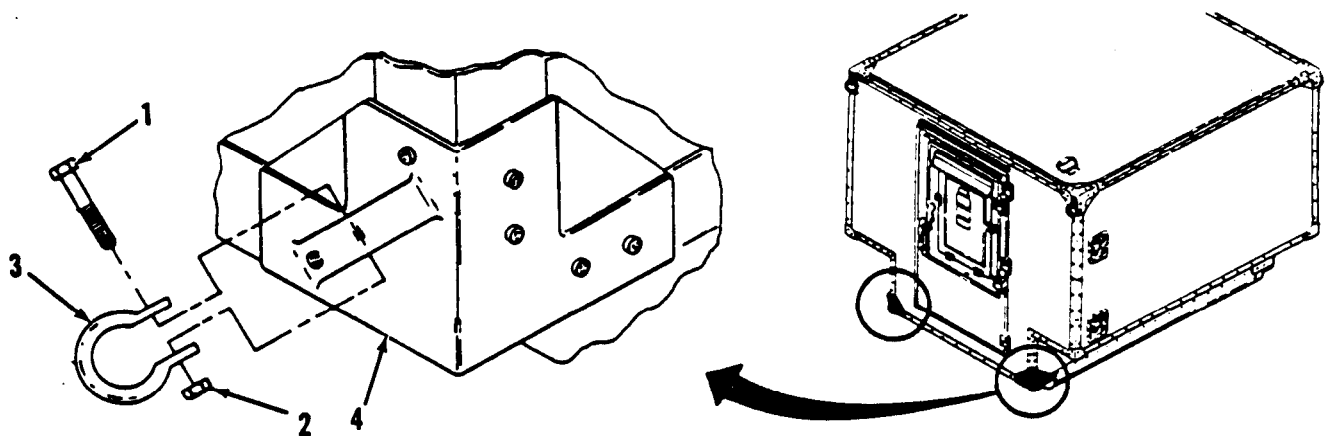

Figure 3-37. Towing Bracket Assembly Repair.

3-35. Lifting Bracket Assembly.

This task covers: a. Inspect
 b. Repair

INITIAL SETUP

Tools

General Mechanic's Automotive Tool Kit

a. Inspect. (Figure 3-38)

- (1) Inspect for free movement and secure mounting.
- (2) Inspect for cracks or other external damage.

b. Repair. (Figure 3-38)

- (1) Remove nut (1) and attaching ring (2) to lifting bracket pin (3) and remove ring.
- (2) Push mounting end of ring (2) through mounting hole of lifting bracket pin (3) and secure with nut (1).

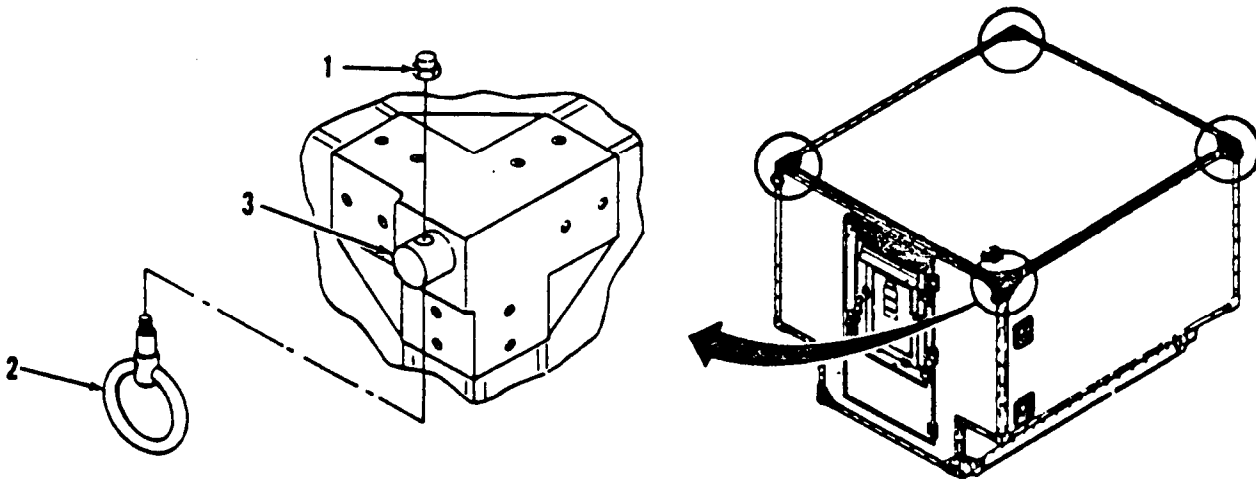

Figure 3-38. Lifting Bracket Assembly Repair.

3-36. Sling Assembly.

This task covers: a. Inspect
 b. Replace

INITIAL SETUP*Tools*

General Mechanic's Automotive Tool Kit

a. Inspect (Figure 3-39)

- (1) Inspect cable assembly for missing or damaged hardware.
- (2) Inspect cable assembly hooks and turnbuckle for proper operation.

b. Replate. (Figure 3-39)

- (1) To replace any of the four cables (1) from the ring assembly (2), open safety snap on attaching hook of cable assembly and remove hook from thimble of ring assembly.
- (2) Push safety hook of new cable assembly (1) to attach the thimble of the ring assembly (2).

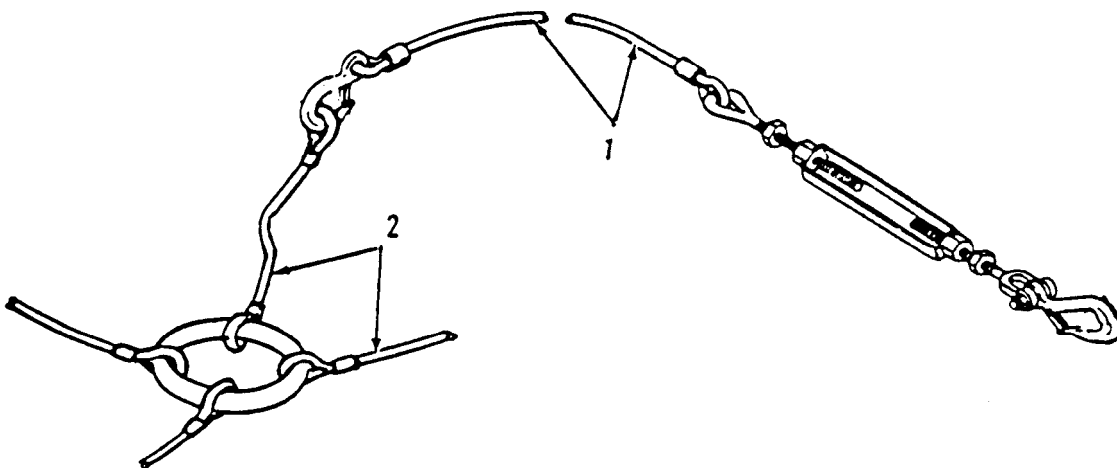

Figure 3-39. Sling Assembly Repair.

Section VI. PREPARATION FOR SHIPMENT AND STORAGE

Subject	Para	Page
General	3-37	3-70
Loading Shelter on a Truck or Rail Car	3-38	3-70
Storing Shelter	3-39	3-70

3-37. General. All items placed inside the shelter must be secured to prevent damage from shock or vibration during transport. The packaging, bracing, cushioning and tie-down method employed must be done so it will not allow damage to wall covering and equipment. Make sure the correct sling assembly is available and in good condition, the skids are in good condition and securely mounted to the shelter, and the drain plug is removed for air or rail transport.

3-38. Loading Shelter on a Truck or Rail Car. The shelter with its payload is capable of being transported by commercial cargo vehicle or any standard 40-foot flatcar as used in the continental United States. During vehicular transport, the shelter should be secured to the transport vehicle or must be crated.

3-39. Storing Shelter. Accumulation of moisture within the shelter resulting from temperature and humidity fluctuations can damage equipment. Minimize moisture accumulation by keeping shelter doors, louver covers, and drain holes open during indoor storage. During outdoor storage, keep doors and drain holes closed, but keep louver covers open.

CHAPTER 4

DIRECT SUPPORT MAINTENANCE INSTRUCTIONS

Subject	Section	Page
Repair Parts, Special Tools, TMDE, and Support Equipment	I	4-1
Troubleshooting	II	4-1
Maintenance Procedures	III	4-2

Section I. REPAIR PARTS, SPECIAL TOOLS, TMDE, AND SUPPORT EQUIPMENT

Subject	Para	Page
Common Tools	4-1	4-1
Special Tools, TMDE, and Support Equipment	4-2	4-1
Repair Parts	4-3	4-1

4-1. **Common Tools.** A complete list of common tools and tool kits is given in Section III of Appendix B, Maintenance Allocation Chart.

4-2. **Special Tools, TMDE, and Support Equipment.** All special tools, TMDE, and support equipment are listed in Section III of Appendix B, Maintenance Allocation Chart, and in the Repair Parts and Special Tools List manual, TM 10-5411-205-23P, S-250/G Shielded and S-250/G Unshielded Electrical Equipment Shelters.

4-3. **Repair Parts,** Repair Parts for direct support maintenance of the shelter are listed and illustrated in TM 10-5411-205-23P.

Section II. TROUBLESHOOTING

4-4. **Troubleshooting.** This section contains troubleshooting information for malfunctions which may develop in the shelter. Fault isolation is limited to those components which may be repaired or replaced at the direct support or general support level. Table 4-1 lists a common malfunction you may encounter during operation or maintenance of the shelter. The malfunction is followed by a list of tests or inspections and corrective actions. These tests or inspections and corrective actions should be performed in the order listed. This manual cannot list all malfunctions that may occur. If you encounter a malfunction that is not listed or cannot be corrected by the listed corrective actions, notify your supervisor.

Table 4-1. Troubleshooting.

**MALFUNCTION
TEST OR INSPECTION
CORRECTIVE ACTION**

1. WATER IS GETTING INTO SHELTER.

- Step 1. Inspect shelter walls and ceiling for leaks.
Patch any holes (paragraph 4-9, 4-10, or 4-11, as applicable).
 - Step 2. Check that all exterior wall and ceiling patches are firmly mounted and bonded to shelter wall.
Apply sealer around edge of patch, or replace patch (paragraph 4-9, 4-10, or 4-11, as applicable).
 - Step 3. Check if lifting bracket assemblies or towing bracket assemblies have pulled away from shelter corners.
 - a. Apply sealer to gaps around bracket edges.
 - b. If replacement is required, notify higher lever of maintenance.
-

Section III. MAINTENANCE PROCEDURES

Subject	Para	Page
General	4 - 5	4 - 2
Shelter Assembly Inspection	4 - 6	4 - 2
Delamination Repair	4 - 7	4 - 3
Repair of Small or Shallow Dent	4 - 8	4 - 7
Repair of Large or Deep Dent	4 - 9	4 - 9
Repair of Small Skin Puncture or Cut	4-10	4-11
Repair of Large Single Skin Puncture or Cut	4-11	4-13
Surface Preparation, Priming, and Painting	4-12	4-16

4-5. General. The general maintenance information given for unit level maintenance also applies to direct support level maintenance. This information is contained in paragraph 3-8.

4-6. Shelter Assembly Inspection. The shelter assembly inspection performed by direct support level maintenance personnel consists of evaluating the damage to the shelter assembly previously identified and noted by unit level maintenance personnel, and determining the proper method of repair.

CAUTION

Any damage to structural members of the shelter will require maintenance beyond the capabilities of the direct support level maintenance facility.

If the inspection of the shelter assembly reveals damage to structural members of the shelter, depot level maintenance personnel should be notified.

47. Delamination Repair.

This task covers: a. Inspect
 b. Repair

INITIAL SETUP

Tools

General Mechanic's Automotive Tool Kit
Riveter

Materials/Parts

Gloves (Item 1, Appendix D)
Caulking Gun (Item 2, Appendix D)
Caulking Cartridge (Item 3, Appendix D)
Epoxy Resin (Items 4 & 5, Appendix D)
Container, Unwaxed (Item 6, Appendix D)
Roller Kit (Item 7, Appendix D)
Tape, Masking (Item 8, Appendix D)
Solvent, Toluene (Item 9, Appendix D)
Cloth, Cotton (Item 10, Appendix D)
Plywood (Item 11, Appendix D)
Polyethylene Sheet (Item 12, Appendix D)
Cloth, Emery (Items 13 & 14, Appendix D)
Sandpaper (Item 15, Appendix D)
Rivet, Countersunk (Item 16, Appendix D)

a. Inspect. The roof, floor, endwalls, and sidewalls are constructed of inner and outer aluminum panels which are attached to structural mounting members. The area between the inner and outer panels is filled with a polyurethane core bonded to the panels with an epoxy adhesive. Separation of aluminum panel and polyurethane core will cause a structural weakness in the area affected. To restore the overall strength of the shelter, large areas of delamination should be repaired as soon as possible. Delaminated areas of the shelter may be detected by movements of the aluminum panel similar to the movement of the bottom of an oil can when pressed. The presence of delaminated areas should produce a light, hollow sound and a bonded area a dull, solid sound. Sound will also change when tapping crosses panel mounting members. When it has been determined that a shelter panel area has been delaminated, repair as follows

b. Repair. (Figure 4-1)

(1) Mark off the limits of delaminated area.

CAUTION

To ensure that opposite shelter wall skin is not punctured, make sure drill bit has a drill stop attached which will prohibit drill bit from exceeding a depth of 5/8 inch.

(2) Using Figure 4-1 as a visual guide, drill a 3/16 inch diameter hole in approximate center of delaminated area of affected panel only. This hole will be used to pump epoxy adhesive into delaminated area.

4-7. **Delamination Repair (cont).**

- (3) Drill 3/16 inch diameter pressure release holes no closer than 1/2 inch from edge of delaminated surface. Number of holes should be determined by size of delamination area. (Release holes should be approximately 2 inches apart.)

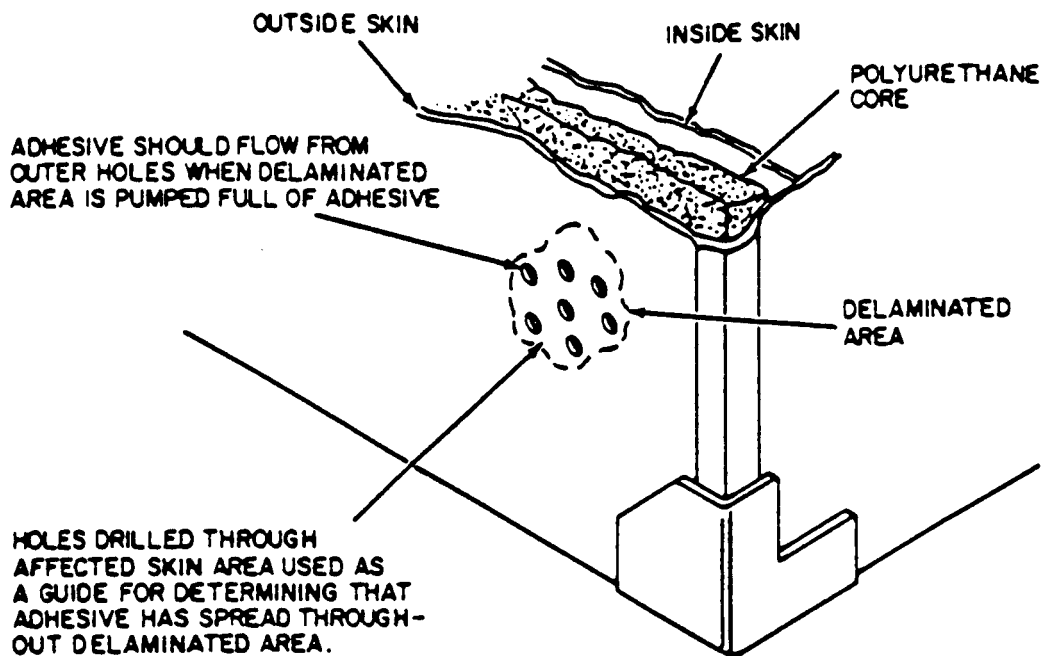

Figure 4-1. Skin Panel Delamination Repair.

WARNING

Gloves are to be worn when mixing and applying adhesive material due to possible skin irritation caused by adhesive coming into contact with the body skin surface.

NOTE

The Versamid material is extremely sensitive to moisture absorption. Therefore, make sure Versamid 140 container has lid firmly replaced after material has been removed from shipping or storage container. Both the Epic R1003 and the Versamid 140 materials have a shelf life of one year.

- (4) Using the outline of the marked delaminated area, mask off the surrounding area (approximately a width of 2 feet) with kraft wrapping paper or newspaper. Using unwaxed clean containers, mix thoroughly the Epic Resin and Versamid material as follows:
- (a) Mixing by weight -- Mix 15 ounces Epic R1003 to 5 ounces of Versamid 140.
 - (b) By volume -- 2 parts of Epic R1003 to 1 part of Versamid 140.

4-7. Delamination Repair (cont).

- (5) Utilizing a plastic cartridge (similar to a caulking cartridge) containing the mixed adhesive material, use a caulking gun to force mixed adhesive directly into the clearance holes in the guidelines as follows

CAUTION

The following repair procedures must be accomplished within one hour of mixing adhesive. Do not attempt any repair unless temperature is between 60°F and 85°F.

- (a) Place nozzle of caulking gun in center hole of delaminated area and inject adhesive into space.
- (b) When space is filled with adhesive, remove caulking gun and using a roller, knead or roll lightly over adhesive filled panel surface, making certain adhesive fills all areas and that air entrapment and surplus adhesive is moved out through pressure release holes.
- (c) Seal center hole with masking tape.

WARNING

Alcohol solvents are flammable. Keep away from heat, sparks, and open flame. Keep containers closed when not used. Use only with adequate ventilation. Avoid prolonged breathing of vapors or repeated contact with skin.

- (d) Using a soft cloth lightly coated with solvent, remove excess adhesive from adhesive filled panel surface.
- (e) Cover adhesive filled panel with a sheet of polyethylene.
- (f) Place a 1/2 inch plywood sheet or equivalent against polyethylene sheet and apply an even surface pressure (bracing is sufficient) over repaired area for at least 24 hours.
- (g) After adhesive has been allowed to cure the required time, remove plywood and polyethylene sheet.
- (h) Sand the repaired area with sandpaper to remove excess cured adhesive.
- (i) Redrill a .190 diameter (#11 drill) by 5/8 inch deep hole at each of the holes previously drilled in paragraphs 4-37. b.(2) and 4-37.b.(3). Slightly countersink the drilled hole with a punch (.062 by 120 degrees) and install a 3/16 inch diameter countersunk pop rivet (AK66H).
- (j) Fill the hollow core portions of pop rivet and any surrounding uneven surface with body filler material, allowing to dry for 1 hour.

4-7. Delamination Repair (cont).

- (k)* Grind repaired surface smooth and using emery cloth or sandpaper, remove any rough areas on surface and thoroughly clean repaired area with a soft cloth lightly coated with alcohol or toluene.
- (l)* Prime and paint repaired panel surface and heads of pop rivets. (Refer to paragraph 4-12.)

48. Repair of Small or Shallow Dent.

This task covers: Repair

INITIAL SETUP*Tools*

General Mechanic's Automotive Tool Kit

Materials/Parts

Cloth, Emery (Item 13, Appendix D)
Sandpaper (Item 15, Appendix D)
Fiber Filled Polyester Resin (Item 17,
Appendix D)

NOTE

The following repair procedures are for a damaged area not exceeding 64-square inches.

Repair. (Figure 4-2)

- (1) Remove all paint or foreign matter from the dent (A, Figure 4-2), and an area approximately three inches wide around the dent, with emery cloth and cleaner.
- (2) Roughen the skin surface with coarse grit emery cloth. Be sure that the area is completely clean. Do not touch the area with hands or wipe with an oily cloth.
- (3) Fill the dent and smooth out evenly as shown in B, Figure 4-2, using any fiber filled polyester resin (body putty).
- (4) Allow the repair mix to set thoroughly in accordance with the manufacturer's recommendations.
- (5) Sand off excess material flush with the contour of the skin surface.
- (6) Prime and paint the repaired surface. (Refer to paragraph 4-2.)

4-8. Repair of Small or Shallow Dent (cont).

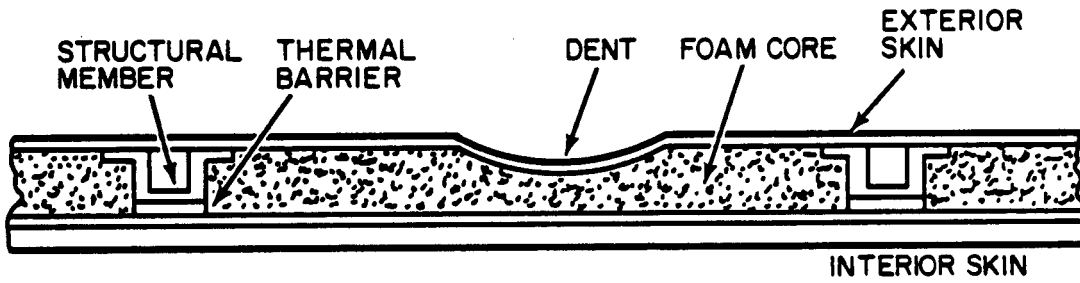

A. SMALL OR SHALLOW DENT IN SANDWICH CONSTRUCTION WITH ALUMINUM STRUCTURAL MEMBERS.

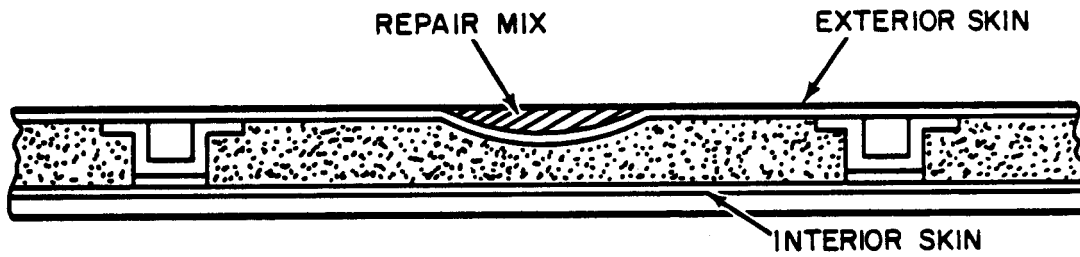

B. REPAIRED SMALL OR SHALLOW DENT.

Figure 4-2. Shelter Wall Repair of Small Dent.

4-9. Repair of Large or Deep Dent.

This task covers: Repair

INITIAL SETUP

Tools

General Mechanic's Automotive Tool Kit

Materials/Parts

Gloves (Item 1, Appendix D)
Caulking Gun (Item 2, Appendix D)
Caulking Cartridge (Item 3, Appendix D)
Epoxy Resin (Items 4 & 5, Appendix D)
Container, Unwaxed (Item 6, Appendix D)
Cloth, Emery (Item 13, Appendix D)
Sandpaper (Item 15, Appendix D)
Fiber Filled Polyester Resin (Item 17, Appendix D)
Cloth, Fiberglass (Item 18, Appendix D)

NOTE

The following repair procedures are for a 64- to 100-square inch area located between structural members. To determine that a large or deep dent is between structural members, tap area with finger. A structural member is identified by a tight, drum-like sound as opposed to the soft sound of areas between members.

Extensive damage, such as denting or buckling of the exterior shelter skin (which displaces the opposite shelter skin) generally constitutes an unrepairable type damage. Follow the procedure in A, B, or C below to repair a large or deep dent involving only the exterior shelter skin.

Repair. (Figure 4-3)

- (1) Perform the procedures contained in paragraph 4-8, steps (1), (2), and (3) using Figure 4-3, A and B.
- (2) Cut a piece of fiberglass cloth that will cover the restored area and extend approximately two inches around the filled-in dent.
- (3) Apply a liberal coating of mixed adhesive (paragraph 4-7.b.(4)) over the filled-in dent extending approximately two inches around the dent.
- (4) Place the fiberglass cloth (C, Figure 4-3) over the coating of mixed adhesive and press lightly.

4-9. Repair of Large or Deep Dent (cont).

- (5) Apply a liberal coating of mixed adhesive over the fiberglass cloth; work from the center of the fiberglass cloth to the extreme edges. Be careful that all edges of the fiberglass cloth are thoroughly saturated.
- (6) Allow the mixed adhesive to set thoroughly and sand off excess.
- (7) Prime and paint the required surface. (Refer to paragraph 4-12.)

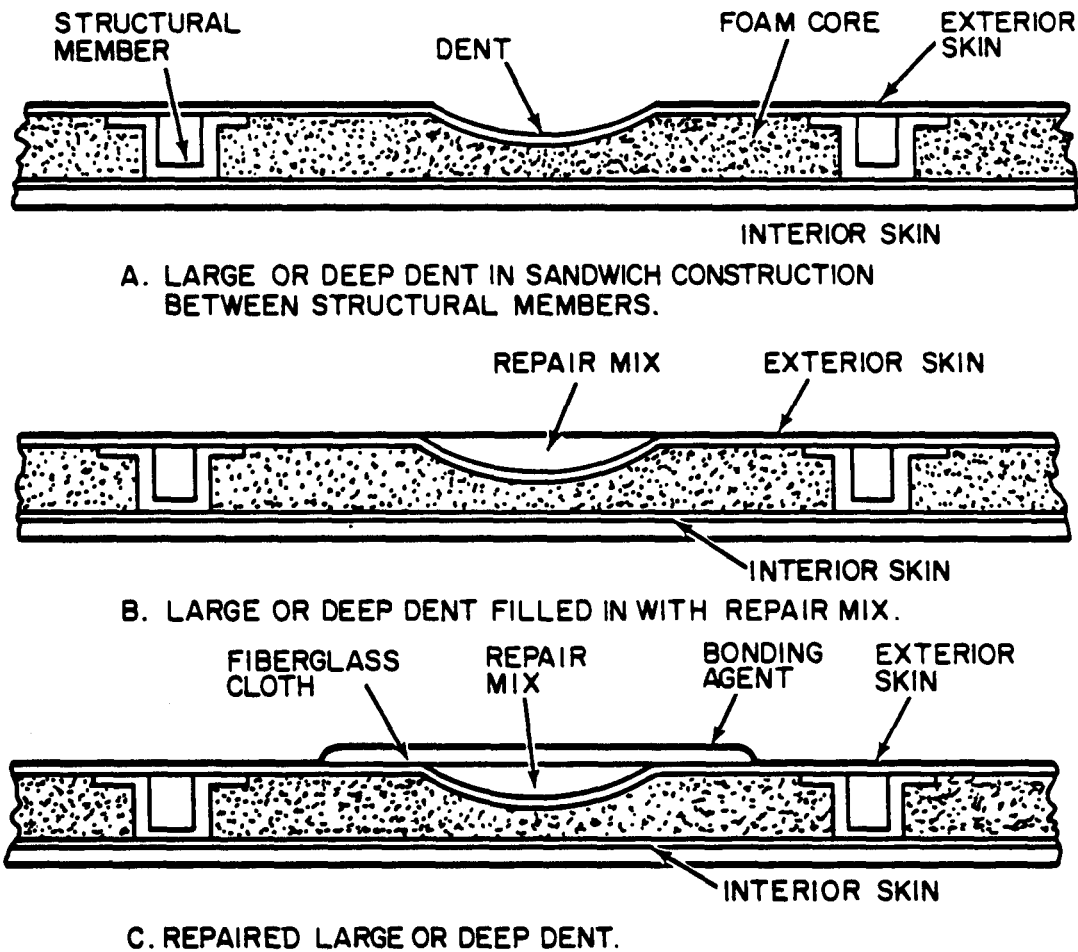

Figure 4-3. Shelter Wall Repair of Large Dent.

4-10. Repair of Small Skin Puncture or Cut.

This task covers: Repair

INITIAL SETUP

Tools

General Mechanic's Automotive Tool Kit
Riveter

Materials/Parts

Gloves (Item 1, Appendix D)
Caulking Gun (Item 2, Appendix D)
Caulking Cartridge (Item 3, Appendix D)
Epoxy Resin (Items 4 & 5, Appendix D)
Container, Unwaxed (Item 6, Appendix D)
Cloth, Cotton (Item 10, Appendix D)
Cloth, Emery (Item 13, Appendix D)
Solvent, Toluene (Item 9, Appendix D)
Aluminum (Item 19, Appendix D)
Rivet, Countersunk (Item 16, Appendix D)

Repair. (Figure 4-4)

- (1) Select an aluminum skin patch that overlaps the puncture or cut by one inch in all directions.
- (2) Position the aluminum skin patch over the puncture and lightly scribe the area of the patch on the shelter skin.
- (3) Remove all paint or foreign matter from the puncture area and an area approximately one inch around the scribed mark using an emery cloth and toluene solvent.
- (4) With the aluminum patch over the puncture area, drill holes for 3/16 inch pop rivets (#11 drill) around the perimeter of the patch, 1/2 inch from the edge of the patch and on one inch centers.
- (5) Roughen the skin surface with coarse grit emery cloth. Be sure that the area is completely clean. Do not touch the area with the hands or wipe with an oily cloth.
- (6) Fill the puncture with a fiber filled polyester resin. Then, smooth out evenly as shown in Figure 4-4, B.
- (7) Allow the resin to set thoroughly. Then, sand off excess flush with the contour of the skin surface.
- (8) Use the aluminum skin patch as a template to mark pop rivet holes in the skin of the shelter, and drill #30 holes in the skin of the shelter.

4-10. Repair of Small Skin Puncture or Cut (cont).

- (9) Coat the back surface of the aluminum skin patch and the shelter skin within the scribe lines with mixed adhesive (paragraph 4-7.b.(4)).
- (10) Position the aluminum skin patch over the repaired area.
- (11) Dip the pop rivets in the mixed adhesive and use the riveting tool for pop rivets to secure the aluminum skin patch to the shelter skin (C, Figure 4-4).
- (12) With a cloth, saturated in toluene solvent, squeeze out and remove immediately any excess mixed adhesive.
- (13) Prime and paint the repaired surface. (Refer to paragraph 4-12.)

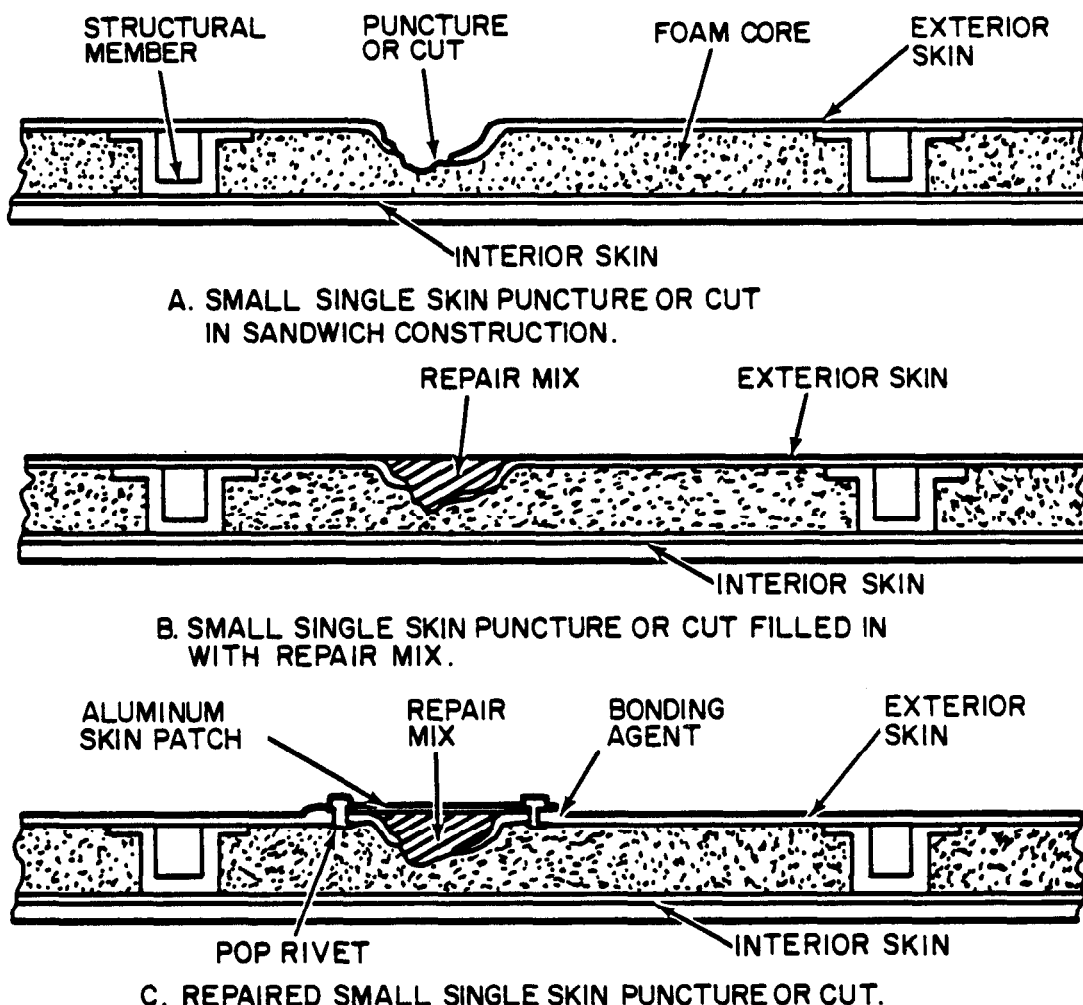

NOTE:
 A GOOD QUALITY COMMERCIAL GLASS FILLED EPOXY RESIN
 MAY BE USED IN PLACE OF REPAIR MIX.

Figure 4-4. Shelter Wall Repair of Small Skin Puncture.

4-11. Repair of Large Single Skin Puncture or Cut.

This task covers: Repair

INITIAL SETUP

Tools

General Mechanic's Automotive Tool Kit
Riveter

Materials/Parts

Gloves (Item 1, Appendix D)
Caulking Gun (Item 2, Appendix D)
Caulking Cartridge (Item 3, Appendix D)
Epoxy Resin (Items 4 & 5, Appendix D)
Container, Unwaxed (Item 6, Appendix D)
Core, Foam (Item 20, Appendix D)
Cloth, Cotton (Item 10, Appendix D)
Cloth, Emery (Item 13, Appendix D)
Solvent, Toluene (Item 9, Appendix D)
Aluminum (Item 19, Appendix D)
Rivet, Countersunk (Item 16, Appendix D)

NOTE

The following repair procedures are for damaged skin between structural members. If the puncture or cut did not seriously damage the foam core, follow the procedures in paragraph 4-9. If the puncture or cut damaged the foam core, follow the procedures below using block insulation or a cutout.

Repair. (Figure 4-5)

- (1) Select an aluminum skin patch that overlaps the puncture or cut by one inch in all directions.
- (2) Use the aluminum skin patch as a template positioned over the puncture or cut, and lightly scribe the area of the aluminum skin patch on the skin of the shelter.
- (3) Use a saw to cut and remove the punctured or cut skin area approximately one inch within the scribed mark (A and B, Figure 4-5).
- (4) Cut the foam core evenly along the edges where the skin is removed and remove the damaged foam core (B, Figure 4-5), maintaining perpendicular and straight edges.
- (5) Select a piece of block insulation or a cutout of the same type sandwich construction (C, Figure 4-5).

4-11. Repair of Large Single Skin Puncture or Cut (cont).

- (6) Size the block insulation or cutout to fit the opening where the skin and foam were removed. If a cutout is used, remove the aluminum skin from one side of the cutout.
- (7) Remove all paint or foreign matter from the overlap area on the skin of the shelter and an area approximately one inch around the scribed mark using emery cloth and cleaner. If the cutout is used, remove all paint or foreign matter from the aluminum skin of the cutout.
- (8) Roughen the skin surface with coarse grit emery cloth. If a cutout is used, roughen the surface of the aluminum skin.
- (9) Coat the interior of the opening where the skin and foam core were removed with mixed adhesive (paragraph 4-7.b.(4)).
- (10) Insert the block insulation or cutout into the opening where the skin and foam core were removed (D, Figure 4-5).
- (11) With the aluminum patch over the puncture area, drill #30 holes, around the perimeter of the patch, 1/2 inch from edge of patch and on one inch centers.
- (12) Coat the exposed block insulation or cutout and the overlap area with mixed adhesive.
- (13) Dip the pop rivets in the mixed adhesive and use the riveting tool for pop rivets to install the aluminum skin patch as shown (E, Figure 4-5).
- (14) Smooth and taper mixed adhesive (squeezed out during the riveting process) along the edges of the aluminum skin patch and immediately remove excess mixed adhesive with cloth saturated in toluene solvent.
- (15) Prime and paint the repaired surface. (Refer to paragraph 4-12.)
- (16) Inspect the repaired area to ensure that rivets and paint were applied correctly.

4-11. Repair of Large Single Skin Puncture or Cut (cont).

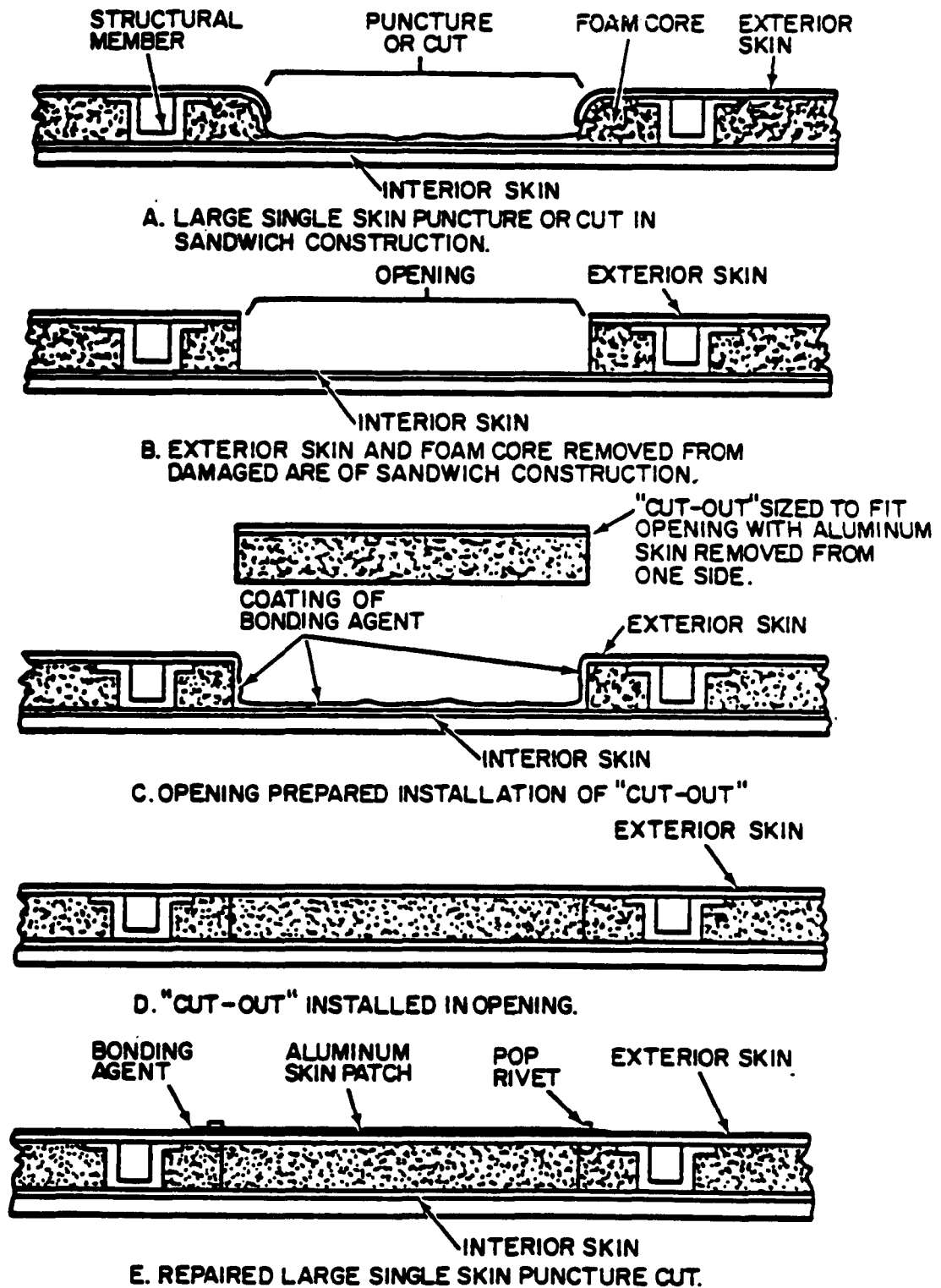

Figure 4-5. Shelter Wall Repair of Large Skin Puncture or Cut.

4-12. Surface Preparation, Priming, and Painting. All bare metal shall be painted to prevent corrosion. Touch up small dents and chips. Repaired sections of panels must be prepared with a corrosion-protection primer before painting. Do not attempt to repaint large areas such as complete exterior, interior, or ceiling. Detailed priming and painting instructions can be found in TM 43-0139.

APPENDIX A

REFERENCES

A-1. Scope. This appendix lists all forms, military specifications, technical manuals and miscellaneous publications referenced in this manual.

A-2. Forms and Records.

Recommended Changes to Publications and Blank Forms	DA Form 2028
Equipment Inspection and Maintenance Worksheet	DA Form 2404
Consolidated Index of Army Publications and Blank Forms	DA Pam 25-30
The Army Maintenance Management System (TAMMS)	DA Pam 738-750
Quality Deficiency Report (QDR)	SF 368
Transportation Discrepancy Report (TDR).	SF 361

A-3. Military Specifications.

Cloth, Cheesecloth, Cotton, Bleached and Unbleached	CCC-C-440
Shelter, Electrical Equipment, S-250/G	MIL-S-55541
Coating, Epoxy, Polyamide	MIL-C-22750
Coating, Aliphatic, Polyurethane, Chemical Agent Resisting	MIL-C-46168
Lubricant, Solid Film, Air Drying, Corrosion Inhibiting	MIL-L-23398
Marking of Electronic Items	MIL-M-13231
Sealing Compound, Temperature-Resistant, Integral Fuel Tank and Fuel Cell Cavities, High Adhesion Sealant	MIL-S-8802
Silicone Compound, NATO Code Number S-736	MIL-S-8660C
Aluminum Alloy, Bar, Rod, Shapes, Tube and Wire; Extruded	QQ-A-20018
Aluminum Alloy 6061, Plate and Sheet	QQ-A-250/11
Thinner, Synthetic Resin, Enamels	TT-T-306
Toluene, Technical Grade	TT-T-548

A-4. Technical Manuals and Bulletins.

Unit, Direct Support and General Support Maintenance Repair Parts and Special Tools Lists for Shelter, Electrical Equipment S-250/G (Shielded) and S-250/G (Unshielded)	TM 10-5411-205-23P
Warranty Program for Electrical Equipment Shelters (Gichner)	TB 10-5411-205-23
Warranty Program for Electrical Equipment Shelters (Ramim)	TB 10-5411-205-23-1
Painting Instructions for Field Use	TM 43-0139
Destruction of Army Materiel to Prevent Enemy Use	TM 750-244-3
Artificial Respiration (First Aid Procedures)	FM 21-11

APPENDIX B

MAINTENANCE ALLOCATION CHART

Section I. INTRODUCTION

B-1. THE ARMY MAINTENANCE SYSTEM MAC

This introduction provides a general explanation of all maintenance and repair functions authorized at the two maintenance levels under the Two-Level Maintenance System concept.

This MAC (immediately following the introduction) designates overall authority and responsibility for the performance of maintenance functions on the identified end item or component. The application of the maintenance functions to the end item or component shall be consistent with the capacities and capabilities of the designated maintenance levels, which are shown on the MAC in column (4) as:

Field - includes two columns, Unit maintenance and Direct Support maintenance. The Unit maintenance column is divided again into two more subcolumns, C for Operator or Crew and O for Unit maintenance.

Sustainment – includes two subcolumns, General Support (H) and Depot (D).

The tools and test equipment requirements (immediately following the MAC) list the tools and test equipment (both special tools and common tool sets) required for each maintenance function as referenced from the MAC.

The remarks (immediately following the tools and test equipment requirements) contain supplemental instructions and explanatory notes for a particular maintenance function.

B-2. MAINTENANCE FUNCTIONS

Maintenance functions will be limited to and are defined as follows:

1. Inspect. To determine the serviceability of an item by comparing its physical, mechanical, and/or electrical characteristics with established standards through examination (e.g., by sight, sound, or feel). This includes scheduled inspection and gagings and evaluation of cannon tubes.
2. Test. To verify serviceability by measuring the mechanical, pneumatic, hydraulic, or electrical characteristics of an item and comparing those characteristics with prescribed standards on a scheduled basis, i.e., load testing of lift devices and hydrostatic testing of pressure hoses.
3. Service. Operations required periodically to keep an item in proper operating condition; e.g., to clean (includes decontaminate, when required), to preserve, to drain, to paint, or to replenish fuel, lubricants, chemical fluids, or gases. This includes scheduled exercising and purging of recoil mechanisms. The following are examples of service functions:
 - a. Unpack. To remove from packing box for service or when required for the performance of maintenance operations.
 - b. Repack. To return item to packing box after service and other maintenance operations.
 - c. Clean. To rid the item of contamination.

- d. Touch up. To spot paint scratched or blistered surfaces.
 - e. Mark. To restore obliterated identification.
4. Adjust. To maintain or regulate, within prescribed limits, by bringing into proper position, or by setting the operating characteristics to specified parameters.
 5. Align. To adjust specified variable elements of an item to bring about optimum or desired performance
 6. Calibrate. To determine and cause corrections to be made or to be adjusted on instruments of test, measuring, and diagnostic equipment used in precision measurement. Consists of comparisons of two instruments, one of which is a certified standard of known accuracy, to detect and adjust any discrepancy in the accuracy of the instrument being compared.
 7. Remove/Install. To remove and install the same item when required to perform service or other maintenance functions. Install may be the act of emplacing, seating, or fixing into position a spare, repair part, or module (component or assembly) in a manner to allow the proper functioning of an equipment or system.
 8. Paint. To prepare and spray color coats of paint so that the ammunition can be identified and protected. The color indicating primary use is applied, preferably, to the entire exterior surface as the background color of the item. Other markings are to be repainted as original so as to retain proper ammunition identification.
 9. Replace. To remove an unserviceable item and install a serviceable counterpart in its place. "Replace" is authorized by the MAC and assigned maintenance level is shown as the third position code of the Source, Maintenance and Recoverability (SMR) code.
 10. Repair. The application of maintenance services, including fault location/troubleshooting, removal/installation, disassembly/assembly procedures and maintenance actions to identify troubles and restore serviceability to an item by correcting specific damage, fault, malfunction, or failure in a part, subassembly, module (component or assembly), end item, or system.

NOTE

The following definitions are applicable to the "repair" maintenance function:

Services. Inspect, test, service, adjust, align, calibrate, and/or replace.

Fault location/troubleshooting. The process of investigating and detecting the cause of equipment malfunctioning; the act of isolating a fault within a system or Unit Under Test (UUT).

Disassembly/assembly. The step-by-step breakdown (taking apart) of a spare/functional group coded item to the level of its least component, that is assigned an SMR code for the level of maintenance under consideration (i.e., identified as maintenance significant).

Actions. Welding, grinding, riveting, straightening, facing, machining, and/or resurfacing.

11. Overhaul. That maintenance effort (service/action) prescribed to restore an item to a completely serviceable/operational condition as required by maintenance standards in appropriate technical publications. Overhaul is normally the highest degree of maintenance performed by the Army. Overhaul does not normally return an item to like new condition.
12. Rebuild. Consists of those services/actions necessary for the restoration of unserviceable equipment to a like new condition in accordance with original manufacturing standards. Rebuild is the highest degree of material maintenance applied to Army equipment. The rebuild operation includes the act of returning to zero those age measurements (e.g., hours/miles) considered in classifying Army equipment/components.

B-3. EXPLANATION OF COLUMNS IN THE MAC, SECTION II

Column (1) Group Number. Column (1) lists Functional Group Code (FGC) numbers, the purpose of which is to identify maintenance significant components, assemblies, subassemblies, and modules with the Next Higher Assembly (NHA).

Column (2) Component/Assembly. Column (2) contains the names of components, assemblies, subassemblies, and modules for which maintenance is authorized.

Column (3) Maintenance Function. Column (3) lists the functions to be performed on the item listed in column (2). (For a detailed explanation of these functions refer to "Maintenance Functions" outlined above).

Column (4) Maintenance Level. Column (4) specifies each level of maintenance authorized to perform each function listed in column (3), by indicating work time required (expressed as manhours in whole hours or decimals) in the appropriate subcolumn. This work time figure represents the active time required to perform that maintenance function at the indicated level of maintenance. If the number or complexity of the tasks within the listed maintenance function varies at different maintenance levels, appropriate work time figures are to be shown for each level. The work time figure represents the average time required to restore an item (assembly, subassembly, component, module, end item, or system) to a serviceable condition under typical field operating conditions. This time includes preparation time (including any necessary disassembly/assembly time), troubleshooting/fault location time, and quality assurance time in addition to the time required to perform the specific tasks identified for the maintenance functions authorized in the MAC. The system designations for the various maintenance levels are as follows:

Field:

- C Operator or Crew maintenance
- O Unit maintenance
- F Direct Support maintenance

Sustainment:

- L Specialized Repair Activity
- H General Support maintenance
- D Depot maintenance

NOTE

The "L" maintenance level is not included in column (4) of the MAC. Functions to this level of maintenance are identified by work time figure in the "H" column of column (4), and an associated reference code is used in the REMARKS column (6). This code is keyed to the remarks and the SRA complete repair application is explained there.

Column (5) Tools and Equipment Reference Code. Column (5) specifies, by code, those common tool sets (not individual tools), common Test, Measurement and Diagnostic Equipment (TMDE), and special tools, special TMDE and special support equipment required to perform the designated function. Codes are keyed to the entries in the tools and test equipment table.

Column (6) Remarks Code. When applicable, this column contains a letter code, in alphabetic order, which is keyed to the remarks table entries.

B-4. EXPLANATION OF COLUMNS IN THE TOOLS AND TEST EQUIPMENT REQUIREMENTS, SECTION III

Column (1) - Tool or Test Equipment Reference Code. The tool or test equipment reference code correlates with a code used in column (5) of the MAC.

Column (2) - Maintenance Level. The lowest level of maintenance authorized to use the tool or test equipment.

Column (3) - Nomenclature. Name or identification of tool or test equipment.

Column (4) - National Stock Number (NSN). The NSN of the tool or test equipment.

Column (5) - Tool Number. The manufacturer's part number.

B-5. EXPLANATION OF COLUMNS IN REMARKS, SECTION IV

Column (1) - Remarks Code. The code recorded in column (6) of the MAC.

Column (2) - Remarks. This column lists information pertinent to the maintenance function being performed as indicated in the MAC.

**Section II. MAINTENANCE ALLOCATION CHART FOR
SHELTER ELECTRICAL EQUIPMENT
S-250/G UNSHIELDED AND S-250/G SHIELDED**

(1) GROUP NUMBER	(2) COMPONENT/ ASSEMBLY	(3) MAINTENANCE FUNCTION	(4) MAINTENANCE LEVEL					(5) TOOLS AND EQUIPMENT REFERENCE CODE	(6) REMARKS CODE
			FIELD		SUSTAINMENT				
			UNIT		DIRECT SUPPORT	GENERAL SUPPORT	DEPOT		
			C	O	F	H	D		
00	SHELTER ASSEMBLY SM-D-649953 (UNSHIELDED) SM-D-650214 (SHIELDED)	Inspect Test Repair		0.2	1.0 5.0			1-5	B,C,D
	TROUGH	Inspect Replace	0.1	0.2			2	B	
	BAIL HANDLE	Inspect Replace	0.1	0.3			2	B	
	RECESSED STEP PAN ASSEMBLY	Inspect Replace	0.1	0.3			2	B	
	DRAIN PLUG	Inspect Replace	0.1	0.2			2	B	
	INSTRUCTION PLATES	Inspect Replace	0.1	0.2			2	B	
	01	DOOR ASSEMBLY, OUTER SM-D-208679	Inspect Service Replace Repair	0.3	0.3 1.7 0.5			2 2,5	A B B
DOOR GASKETS		Inspect Test Adjust Replace	0.1	0.2 2.4 1.5			2	B B	
DOOR HANDLE ASSEMBLY AND LATCHING MECHANISM		Inspect Service Repair	0.2	0.3 1.0			2	A B	
KEEPER ASSEMBLY		Inspect Replace	0.1	0.5			2	B	
HINGE ASSEMBLY		Inspect Replace	0.1	0.5			2	B	
DOOR HASP		Inspect Replace	0.1	0.2			2	B	

**Section II. MAINTENANCE ALLOCATION CHART FOR
SHELTER ELECTRICAL EQUIPMENT
S-250/G UNSHIELDED AND S-250/G SHIELDED - continued**

(1) GROUP NUMBER	(2) COMPONENT/ ASSEMBLY	(3) MAINTENANCE FUNCTION	(4) MAINTENANCE LEVEL					(5) TOOLS AND EQUIPMENT REFERENCE CODE	(6) REMARKS CODE	
			FIELD		SUSTAINMENT					
			UNIT	DIRECT SUPPORT	GENERAL SUPPORT	DEPOT				
			C	O	F	H	D			
02	DOOR ASSEMBLY, INNER SM-D-208682	Inspect	0.3					2		
		Test		0.2						
		Adjust		2.4					2	
		Service		0.3						A
		Replace		1.7					2	B
	Repair		0.5					2,5	B	
0201	LOUVER ASSEMBLY, HOLDER ASSEMBLY AND RFI/EMI FILTER	Inspect	0.2							
		Repair		1.7					2	B
	DIRECTIONAL VANE ASSEMBLY AND AIR INTAKE FILTER	Inspect	0.1							
		Replace		1.0					2	B
	LOUVER COVER ASSEMBLY LATCHES	Inspect	0.1							
		Replace		0.4					2	B
SHIELD (RAIN FLAP)	Inspect	0.1								
Replace		0.4					2	B		
0201	LOWER AND COVER ASSEMBLY SM-2-435911	Inspect	0.1							
		Replace		0.7						
	Repair		1.7					2,5	B	
	DATA PLATES	Inspect	0.1							
		Repair		0.2					2	B
LOUVER COVER ASSEMBLY STRIKES	Inspect	0.1								
Replace		0.5					2	B		
03	DOOR STAY ASSEMBLY SC-D-435914	Inspect	0.2						5	
		Service		0.1						
		Replace		1.8					2	B
		Repair		0.7					2,5	B

**Section II. MAINTENANCE ALLOCATION CHART FOR
SHELTER ELECTRICAL EQUIPMENT
S-250/G UNSHIELDED AND S-250/G SHIELDED - continued**

(1) GROUP NUMBER	(2) COMPONENT/ ASSEMBLY	(3) MAINTENANCE FUNCTION	(4) MAINTENANCE LEVEL					(5) TOOLS AND EQUIPMENT REFERENCE CODE	(6) REMARKS CODE	
			FIELD		SUSTAINMENT					
			UNIT		DIRECT SUPPORT	GENERAL SUPPORT	DEPOT			
			C	O	F	H	D			
04	SKID ASSEMBLY SM-D-650082	Inspect Replace	0.1	3.7				2,5	B	
05	TOWING BRACKET ASSEMBLY SM-C-249315 GRI & GRII	Inspect Repair	0.1	0.2				2	B	
06	LIFTING BRACKET ASSEMBLY SM-C-650075 GRI & GRII	Inspect Repair	0.1	0.2				2	B	
07	SLING ASSEMBLY SC-D-649952	Inspect Repair	0.1	0.2				2	B	

**Section III. TOOL AND TEST EQUIPMENT REQUIREMENTS FOR
SHELTER ELECTRICAL EQUIPMENT S-250/G UNSHIELDED AND S-250/G SHIELDED**

(1) TOOL OR TEST EQUIPMENT REFERENCE CODE	(2) MAINTENANCE LEVEL	(3) NOMENCLATURE	(4) NATIONAL STOCK NUMBER	(5) TOOL NUMBER
1	O	Tool Kit	5180-00-610-8177	TK-105/G
2	F, O	Tool Kit, Automotive	5180-00-177-7033	SC5180-90-CL-N26
3	F	Tool Kit	5180-00-973-4369	TK-144/G
4	O	Riveter, Blind Hand	5120-00-224-9298	C-6006-32
5	O	Drill, Electric	5130-00-889-8994	WD00661

**Section IV. REMARKS FOR
SHELTER ELECTRICAL EQUIPMENT S-250/G UNSHIELDED AND S-250/G SHIELDED**

(1) REMARKS CODE	(2) REMARKS
A	Lubricate hinges and door mechanism, replace door filter, touchup paint
B	Replace damaged part
C	Skin damage
D	Skin damage, thread fastened parts, gaskets
E	Replace entire assembly. No repair parts functional group code assigned

APPENDIX C

COMPONENTS OF END ITEM AND BASIC ISSUE ITEMS LISTS

Section I. INTRODUCTION

C-1. SCOPE.

This appendix lists components of end item and basic issue items for the S-250/G Unshielded S-250/G Shielded Shelters to help you inventory items required for safe and efficient operation.

C-2. GENERAL.

The Components of End Item and Basic Issue Items Lists are divided into the following sections:

a. Section II. Components of End Item. This listing is for informational purposes only, and is not authority to requisition replacements. These items are part of the end item, but are removed and separately packaged for transportation or shipment. As part of the end item, these items must be with the end item whenever it is issued or transferred between property accounts. Illustrations are furnished to assist you in identifying the items.

b. Section III. Basic Issue Items. These are the minimum essential items required to place the S-250/G Unshielded S-250/G Shielded Shelters in operation, to operate them, and to perform emergency repairs. Although shipped separately packaged, BII must be with the shelters during operation and whenever they are transferred between property accounts. The illustrations will assist you with hard-to-identify items. This manual is your authority to request/requisition replacement BII, based on TOE/MTOE authorization; of the end item.

C-3. EXPLANATION OF COLUMNS

The following provides an explanation of columns found in the tabular listings:

a. Column (1) - Illustration Number (Illus Number). This column indicates the number of the illustration in which the item is shown.

b. Column (2) - National Stock Number. Indicates the National stock number assigned to the item and will be used for requisitioning purposes.

c. Column (3) - Description. Indicates the Federal item name and, if required, a minimum description to identify and locate the item. The last line for each item indicates the FSCM (in parentheses) followed by the part number.

d. Column (4) - Unit of Measure (U/M). Indicates the measure used in performing the actual operational/maintenance function. This measure is expressed by a two-character alphabetical abbreviation (e.g., ea, in, pr).

e. Column (5) - Quantity required (Qty rqr). Indicates the quantity of the item authorized to be used with/on the equipment.

Section II. COMPONENTS OF END ITEM

(1) ILLUS NO.	(2) NATIONAL STOCK NUMBER	(3) DESCRIPTION FSCM AND PART NUMBER	USABLE ON CODE	(4) U/M U/M	(5) QTY. REQ.
---------------------	---------------------------------	--	-------------------	-------------------	---------------------

Section III. BASIC ISSUE ITEMS

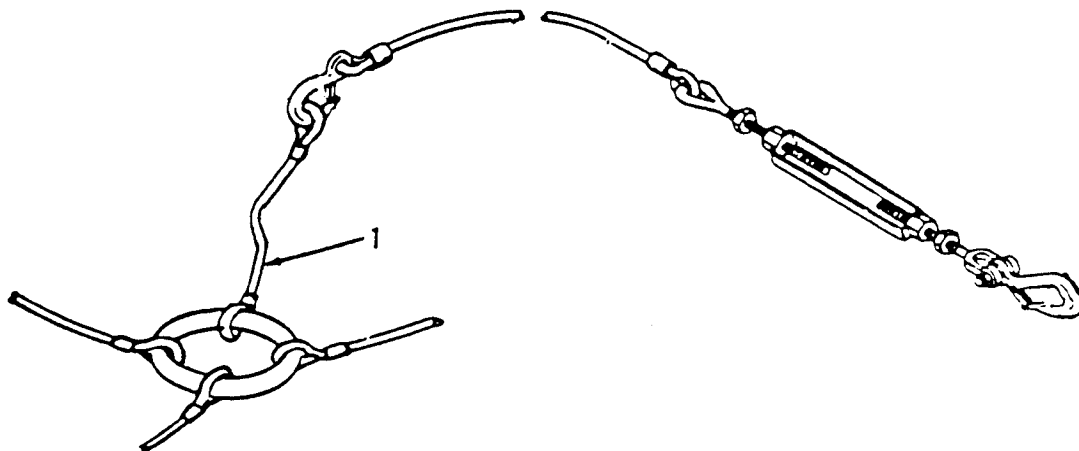

(1) ILLUS NO.	(2) NATIONAL STOCK NUMBER	(3) DESCRIPTION AND PART NUMBER	(4) USABLE U/M ON CODE U/M	(5) QTY. REQ.
1	3940-00-115-6380	SLING ASSEMBLY (81337) SM-D-649952	EA	1

APPENDIX D

EXPENDABLE/DURABLE SUPPLIES AND MATERIALS LIST

Section I. INTRODUCTION

D-1. SCOPE.

This appendix lists expendable/durable supplies and materials you will need to operate and maintain the S-250/G Unshielded and S-250/G Shielded Shelters. These items are authorized to you by CTA 50-970, Expendable/Durable Items (Except Medical, Class V, Repair Parts, and Heraldic Itms), or CTA 8-100, Army Medical Department Expendable/Durable Items.

D-2. EXPLANATION OF COLUMNS.

- a. Column (1) - Item number. This number is assigned to the entry in the listing.
- b. Column (2) - Level. This column identifies the lowest level of maintenance that requires the listed item.

(Enter as applicable.)

- C - Operator
- O - Unit Maintenance
- F - Direct Support Maintenance
- H - General Support Maintenance

c. Column (3) - National Stock Number. This is the National stock number assigned to the item, use it to request or requisition the item.

d. Column (4) - Description. Indicates the Federal item name and, if required, a description to identify the item. The last line for each item indicates the Federal Supply Code for Manufacturer (FSCM) in parentheses followed by the part number.

e. Column (5) - Unit of Measure (U/M). Indicates the measure used in performing the actual maintenance function. This measure is expressed by a two-character alphabetical abbreviation (e.g., ea, in, pr). If the unit of measure differs from the unit of issue, requisition the lowest unit of issue that will satisfy your requirements.

Section II. EXPENDABLE SUPPLIES AND MATERIALS LIST

(1) ITEM NO.	(2) LEVEL	(3) NATIONAL STOCK NUMBER	(4) DESCRIPTION	(5) U/M
1	F	8415-00-634-5021	Gloves, JJ-G-451	pr
2	F		Caulking gun, 10-1/2"L x 3/8" Oval Tip	ea
3	F		Caulking cartridge blank)	ea
4	F		Epoxy resin, Epic R1003	gl
5	F	8040-00-222-9059	Epoxy resin, Versamid 140	gl

Section II. EXPENDABLE SUPPLIES AND MATERIALS LIST (cont)

(1) ITEM NO.	(2) LEVEL	(3) NATIONAL STOCK NUMBER	(4) DESCRIPTION	(5) U/M
6	F		Container, unwaxed, 16 oz. UU-C-80611	ea
7	F	8020-00-689-5379	Roller Kit, H-R-550	ea
8	F	7510-00-266-6710	Tape, masking	rl
9	F		Solvent, Toluene, TT-T-548	gl
10	F	6850-00-948-5853	Cloth, cotton	yd
11	F		Plywood, 1/2" thick 3' X 3'	sh
12	F		Polyethylene sheet	sh
13	F	5350-00-253-4393	Cloth, emery, coarse grit, 60 grit	ah
14	F	5350-00-161-9066	Cloth, emery, fine grit, 100 grit	sh
15	F	5350-00-192-5046	Sandpaper, 60 grit	sh
16	F		Rivet, countersunk, AK66H	ea
17	F		Fiber filled polyester resin	gl
18	F		Cloth, fiberglass	sh
19	F		Aluminum sheet, .040 in. thick QQ-A-250/11, 6061-T6	sh
20	F		Polyethylene, sheet	sh
21	O	9150-01-260-2534	Lubricant, solid film	oz
22	O	9150-00-954-7422	Lubricant, solid film	qt
23	O		Paint, lusterless green No. 383, polyurethane, MIL-C-4618	gl
24	O		Paint, polyamide epoxy, MIL-C-22750	gl
25	O	5315-00-078-0112	Pin, headless, straight, MS16556-608	ea
26	O	8040-01-133-3304	Sealer, silicone, 138 RTV	tb
27	O		Gasket, silicone (81337) SM-C-564839	ft
28	O	8030-00-753-5005	Sealing compound, 6 oz., MIL-S-8802D	oz
29	O	7610-00-266-6714	Tape, polyethylene coated	rl
30	O	8040-00-078-9774	Adhesive, Selastic, 732 RTV	tb

Section II. EXPENDABLE SUPPLIES AND MATERIALS LIST (cont)

(1) ITEM NO.	(2) LEVEL	(3) NATIONAL STOCK NUMBER	(4) DESCRIPTION	(5) U/M
31	F		Shield, EM (80063) SM-B-564670	ro
32	F		Tape (80063) SM-B-450436	ro
33	F		Conductive Compound (81337) SM-B-563756	gl
34	F	9320-00-202-4008	Rubber, solid sheet, 1/8" thick	sh

I N D E X

Subject	Page
A	
Abbreviations, list of	1-2
Air intake filter	3-51
B	
Bail handle replacement	3-26
C	
D	
Data, equipment	1-3
Data plates, repair	3-58
Destruction of Army materiel to prevent enemy use	1-1
Directional vane assembly and air intake filter	
Inspect	3-51
Replace	3-51
Door assembly, inner	
Inspect	3-46
Remove	3-46
Repair	3-46
Install	3-47
Door assembly, outer	
Inspect	3-31
Remove	3-31
Repair	3-31
Install	3-32
Door gaskets	
Inspect	3-33
Test	3-33
Adjust	3-34
Replace	3-35
Door handle assembly and latching mechanism	
Inspect	3-37
Service	3-37
Disassemble	3-37
Assemble	3-38
Repair	3-39
Door hasp replacement	3-45
Door stay assembly	
Inspect	3-61
Remove	3-61
Disassemble	3-61
Repair	3-61
Assemble	3-62
Install	3-62
Drain plug replacement	3-29

INDEX (cont)

Subject	Page
E	
Equipment characteristics, capabilities, and features	1-2
Equipment description and data	1-2
Expendable/durable materials	D-1
F	
G	
Gaskets, door	
Inspect	3-33
Test	3-33
Adjust	3-34
Replace	3-35
H	
Hinge assembly	
Inspect	3-43
Remove	3-43
Disassemble	3-43
Assemble	3-43
Install	3-44
Holder assembly	3-48
How to use this manual	iv
I	
Instruction plates	1-4
Instruction plates, replacement	3-30
J	
K	
Keeper assembly	
Inspect	3-41
Replace	3-41
L	
Lifting bracket assembly	
Inspect	3-68
Replace	3-68
Lifting shelter	3-2
Lifting shelter onto clock	3-2
Loading shelter onto truck or rail car	3-70
Location and description of major components	1-2

INDEX (cont)

Subject	Page
Louver assembly, holder assembly and RFI/EMI filter	
Inspect	3-48
Remove	3-48
Repair	3-48
Install	3-48
Louver cover assembly	
Inspect	3-56
Remove	3-56
Repair	3-56
Install	3-56
Louver cover assembly clips, replacement	3-60
Louver cover assembly latches	
Inspect	3-53
Replace	3-53
Louver cover assembly	3-59
Lubrication	3-1
M	
Maintenance allocation	B-1
Maintenance forms and records	1-1
Maintenance instructions	
Direct support	3-11
General support	3-11
Marking, shelter	1-4
N	
O	
Operating instructions	2-1
Unusual conditions	2-4
Usual conditions	2-4
P	
Painting, surface preparation, priming	4-16
Panel repair	
Delamination	4-3
Large or deep dent	4-9
Large single & skin puncture or cut..	4-13
Small or shallow dent	4-7
Small skin puncture or cut.	4-11
Temporary	3-20
Plates, data repair	3-58
Preparation for-shipment and storage	1-1, 3-70
Preventive Maintenance Checks and Services (PMCS), operator	2-1

INDEX (cont)

Subject	Page
Q	
R	
Rain flap (shield) replacement	3-55
Recessed step pan assembly replacement	3-27
References	A - 1
Repair parts	3 - 1
Repair procedures, general..	3-12
Reporting equipment improvement recommendations	1-1
RFI/EMI filter	3-48
Rivet installation and removal	3-12
Rivnut installation and removal	3-16

S

Safety, care and handling	1 - 5
Securing shelter on 1-1/4 ton (M561 or M715) truck	3 - 4
Securing shelter on 1-1/4ton (M880) truck	3 - 5
Securing shelter on M1028 carrier	3 - 7
Service upon receipt	3 - 1
Shield (rain flap) replacement	3-55
Site requirements	3 - 7
Skid assembly	
Inspect	3-63
Remove	3-63
Disassemble	3-64
Repair	3-64
Assemble	3-64
Install	3-65
Sling assembly	
Inspect	3-69
Replace	3-69
Step assembly (recessed) replacement	3-27
Storing shelter	3-70
Surface preparation, priming, and painting	4-16

T

Troubleshooting	3-7, 4-2
Trough	3-25
Towing bracket assembly	
Inspect	3-67
Replace	3-67

U

V

INDEX (cont)

Subject Page

W

Warning plates	1-4
Warranty information	1-2

X

Y

Z

By Order of the Secretary of the Army

CARL E. VUONO
General, United States Army
Chief of Staff

Official:

WILLIAM J. MEEHAN, II
Brigadier General, United States Army
The Adjutant General

DISTRIBUTION:

To be distributed in accordance with DA Form 12-25E, Operator's, Unit, and Direct Support and General Support Maintenance requirements for Shelter, Expandable, 1-Side (5-4-2828-2).

These are the instructions for sending an electronic 2028

The following format must be used if submitting an electronic 2028. The subject line must be exactly the same and all fields must be included; however only the following fields are mandatory: 1, 3, 4, 5, 6, 7, 8, 9, 10, 13, 15, 16, 17, and 27.

From: "Whomever" <whomever@avma27.army.mil>
To: amssbriml@natick.army.mil

Subject: DA Form 2028

1. From: Joe Smith
2. Unit: home
3. Address: 4300 Park
4. City: Hometown
5. St: MO
6. Zip: 77777
7. Date Sent: 19-OCT-93
8. Pub no: 55-2840-229-23
9. Pub Title: TM
10. Publication Date: 04-JUL-85
11. Change Number: 7
12. Submitter Rank: MSG
13. Submitter FName: Joe
14. Submitter MName: T
15. Submitter LName: Smith
16. Submitter Phone: 123-123-1234
17. Problem: 1
18. Page: 2
19. Paragraph: 3
20. Line: 4
21. NSN: 5
22. Reference: 6
23. Figure: 7
24. Table: 8
25. Item: 9
26. Total: 123
27. Text:

This is the text for the problem below line 27.

RECOMMENDED CHANGES TO PUBLICATIONS AND BLANK FORMS For use of this form, see AR 25-30; the proponent agency is ODISC4.						Use Part II (<i>reverse</i>) for Repair Parts and Special Tool Lists (RPSTL) and Supply Catalogs/Supply Manuals (SC/SM).	DATE <i>21 October 2003</i>
TO: (<i>Forward to proponent of publication or form</i>) (<i>Include ZIP Code</i>) COMMANDER U.S. ARMY TANK-AUTOMOTIVE AND ARMAMENT COMMAND ATTN: AMSTA-LC-CECT 15 KANSAS STREET NATICK, MA 01760-5052						FROM: (<i>Activity and location</i>) (<i>Include ZIP Code</i>) <i>PFC Jane Doe</i> <i>CO A 3rd Engineer BR</i> <i>Ft. Leonardwood, MO 63108</i>	
PART I – ALL PUBLICATIONS (EXCEPT RPSTL AND SC/SM) AND BLANK FORMS							
PUBLICATION/FORM NUMBER TM 10-1670-296-23&P				DATE 30 October 2002	TITLE Unit Manual for Ancillary Equipment for Low Velocity Air Drop Systems		
ITEM NO.	PAGE NO.	PARA-GRAPH	LINE NO. *	FIGURE NO.	TABLE NO.	RECOMMENDED CHANGES AND REASON <i>(Provide exact wording of recommended changes, if possible).</i>	
	0036 00-2				1	<i>In table 1, Sewing Machine Code Symbols, the second sewing machine code symbol should be MD ZZ not MD 22.</i> <i>Change the manual to show Sewing Machine, Industrial: Zig-Zag; 308 stitch; medium-duty; NSN 3530-01-181-1421 as a MD ZZ code symbol.</i>	
<i>*Reference to line numbers within the paragraph or subparagraph.</i>							
TYPED NAME, GRADE OR TITLE Jane Doe, PFC				TELEPHONE EXCHANGE/AUTOVON, PLUS EXTENSION 508-233-4141		SIGNATURE Jane Doe <i>Jane Doe</i>	

TO: <i>(Forward direct to addressee listed in publication)</i> COMMANDER U.S. ARMY TANK-AUTOMOTIVE AND ARMAMENT COMMAND ATTN: AMSTA-LC-CECT 15 KANSAS STREET NATICK, MA 01760-5052	FROM: <i>(Activity and location) (Include ZIP Code)</i> <i>PFC Jane Doe</i> <i>CO A 3rd Engineer BR</i> <i>Ft. Leonardwood, MO 63108</i>	DATE 21 October 2003
--	---	--------------------------------

PART II – REPAIR PARTS AND SPECIAL TOOL LISTS AND SUPPLY CATALOGS/SUPPLY MANUALS

PUBLICATION NUMBER TM 10-1670-296-23&P	DATE 30 October 2002	TITLE Unit Manual for Ancillary Equipment for Low Velocity Air Drop Systems
--	--------------------------------	---

PAGE NO.	COLM NO.	LINE NO.	NATIONAL STOCK NUMBER	REFERENCE NO.	FIGURE NO.	ITEM NO.	TOTAL NO. OF MAJOR ITEMS SUPPORTED	RECOMMENDED ACTION
0066 00-1					4			<i>Callout 16 in figure 4 is pointed to a <u>D-Ring</u>. In the Repair Parts List key for figure 4, item 16 is called a <u>Snap Hook</u>. Please correct one or the other.</i>

SAMPLE

PART III – REMARKS *(Any general remarks or recommendations, or suggestions for improvement of publications and blank forms. Additional blank sheets may be used if more space is needed.)*

TYPED NAME, GRADE OR TITLE	TELEPHONE EXCHANGE/AUTOVON, PLUS EXTENSION	SIGNATURE
----------------------------	--	-----------

<p align="center">RECOMMENDED CHANGES TO PUBLICATIONS AND BLANK FORMS</p> <p>For use of this form, see AR 25-30; the proponent agency is ODISC4.</p>						Use Part II (<i>reverse</i>) for Repair Parts and Special Tool Lists (RPSTL) and Supply Catalogs/Supply Manuals (SC/SM).	DATE
TO: (<i>Forward to proponent of publication or form</i>) (<i>Include ZIP Code</i>) COMMANDER U.S. ARMY TANK-AUTOMOTIVE AND ARMAMENT COMMAND ATTN: AMSTA-LC-CECT 15 KANSAS STREET NATICK, MA 01760-5052						FROM: (<i>Activity and location</i>) (<i>Include ZIP Code</i>)	
PART I - ALL PUBLICATIONS (EXCEPT RPSTL AND SC/SM) AND BLANK FORMS							
PUBLICATION/FORM NUMBER TM 10-5411-205-13				DATE 5 May 1990	TITLE Operator's, Unit, and Direct Support Maintenance Manual For Shelter, Electrical Equipment Shielded and Unshielded		
ITEM NO.	PAGE NO.	PARA-GRAPH	LINE NO. *	FIGURE NO.	TABLE NO.	RECOMMENDED CHANGES AND REASON <i>(Provide exact wording of recommended changes, if possible).</i>	
<i>*Reference to line numbers within the paragraph or subparagraph.</i>							
TYPED NAME, GRADE OR TITLE				TELEPHONE EXCHANGE/AUTOVON, PLUS EXTENSION		SIGNATURE	

TO: <i>(Forward direct to addressee listed in publication)</i> COMMANDER U.S. ARMY TANK-AUTOMOTIVE AND ARMAMENT COMMAND ATTN: AMSTA-LC-CECT 15 KANSAS STREET NATICK, MA 01760-5052	FROM: <i>(Activity and location) (Include ZIP Code)</i>	DATE
---	---	------

PART II - REPAIR PARTS AND SPECIAL TOOL LISTS AND SUPPLY CATALOGS/SUPPLY MANUALS

PUBLICATION NUMBER TM 10-5411-205-13	DATE 5 May 1990	TITLE Operator's, Unit, and Direct Support Maintenance Manual For Shelter, Electrical Equipment Shielded and Unshielded
---	--------------------	---

PAGE NO.	COLM NO.	LINE NO.	NATIONAL STOCK NUMBER	REFERENCE NO.	FIGURE NO.	ITEM NO.	TOTAL NO. OF MAJOR ITEMS SUPPORTED	RECOMMENDED ACTION

PART III - REMARKS *(Any general remarks or recommendations, or suggestions for improvement of publications and blank forms. Additional blank sheets may be used if more space is needed.)*

TYPED NAME, GRADE OR TITLE	TELEPHONE EXCHANGE/AUTOVON, PLUS EXTENSION	SIGNATURE
----------------------------	--	-----------

<p align="center">RECOMMENDED CHANGES TO PUBLICATIONS AND BLANK FORMS</p> <p>For use of this form, see AR 25-30; the proponent agency is ODISC4.</p>						Use Part II (<i>reverse</i>) for Repair Parts and Special Tool Lists (RPSTL) and Supply Catalogs/Supply Manuals (SC/SM).	DATE
TO: (<i>Forward to proponent of publication or form</i>) (<i>Include ZIP Code</i>) COMMANDER U.S. ARMY TANK-AUTOMOTIVE AND ARMAMENT COMMAND ATTN: AMSTA-LC-CECT 15 KANSAS STREET NATICK, MA 01760-5052						FROM: (<i>Activity and location</i>) (<i>Include ZIP Code</i>)	
PART I - ALL PUBLICATIONS (EXCEPT RPSTL AND SC/SM) AND BLANK FORMS							
PUBLICATION/FORM NUMBER TM 10-5411-205-13				DATE 5 May 1990		TITLE Operator's, Unit, and Direct Support Maintenance Manual For Shelter, Electrical Equipment Shielded and Unshielded	
ITEM NO.	PAGE NO.	PARA-GRAPH	LINE NO. *	FIGURE NO.	TABLE NO.	RECOMMENDED CHANGES AND REASON (<i>Provide exact wording of recommended changes, if possible.</i>)	
<i>*Reference to line numbers within the paragraph or subparagraph.</i>							
TYPED NAME, GRADE OR TITLE				TELEPHONE EXCHANGE/AUTOVON, PLUS EXTENSION		SIGNATURE	

TO: <i>(Forward direct to addressee listed in publication)</i> COMMANDER U.S. ARMY TANK-AUTOMOTIVE AND ARMAMENT COMMAND ATTN: AMSTA-LC-CECT 15 KANSAS STREET NATICK, MA 01760-5052	FROM: <i>(Activity and location) (Include ZIP Code)</i>	DATE
---	---	------

PART II - REPAIR PARTS AND SPECIAL TOOL LISTS AND SUPPLY CATALOGS/SUPPLY MANUALS

PUBLICATION NUMBER TM 10-5411-205-13	DATE 5 May 1990	TITLE Operator's, Unit, and Direct Support Maintenance Manual For Shelter, Electrical Equipment Shielded and Unshielded
---	--------------------	---

PAGE NO.	COLM NO.	LINE NO.	NATIONAL STOCK NUMBER	REFERENCE NO.	FIGURE NO.	ITEM NO.	TOTAL NO. OF MAJOR ITEMS SUPPORTED	RECOMMENDED ACTION

PART III - REMARKS *(Any general remarks or recommendations, or suggestions for improvement of publications and blank forms. Additional blank sheets may be used if more space is needed.)*

Empty space for remarks

TYPED NAME, GRADE OR TITLE	TELEPHONE EXCHANGE/AUTOVON, PLUS EXTENSION	SIGNATURE
----------------------------	--	-----------

The Metric System and Equivalents

Linear Measure

1 centimeter = 10 millimeters = .39 inch
 1 decimeter = 10 centimeters = 3.94 inches
 1 meter = 10 decimeters = 39.37 inches
 1 dekameter = 10 meters = 32.8 feet
 1 hectometer = 10 dekameters = 328.08 feet
 1 kilometer = 10 hectometers = 3,280.8 feet

Weights

1 centigram = 10 milligrams = .15 grain
 1 decigram = 10 centigrams = 1.54 grains
 1 gram = 10 decigram = .035 ounce
 1 dekagram = 10 grams = .35 ounce
 1 hectogram = 10 dekagrams = 3.52 ounces
 1 kilogram = 10 hectograms = 2.2 pounds
 1 quintal = 100 kilograms = 220.46 pounds
 1 metric ton = 10 quintals = 1.1 short tons

Liquid Measure

1 centiliter = 10 milliliters = .34 fl. ounce
 1 deciliter = 10 centiliters = 3.38 fl. ounces
 1 liter = 10 deciliters = 33.81 fl. ounces
 1 dekaliter = 10 liters = 2.64 gallons
 1 hectoliter = 10 dekaliters = 26.42 gallons
 1 kiloliter = 10 hectoliters = 264.18 gallons

Square Measure

1 sq. centimeter = 100 sq. millimeters = .155 sq. inch
 1 sq. decimeter = 100 sq. centimeters = 15.5 sq. inches
 1 sq. meter (centare) = 100 sq. decimeters = 10.76 sq. feet
 1 sq. dekameter (are) = 100 sq. meters = 1,076.4 sq. feet
 1 sq. hectometer (hectare) = 100 sq. dekameters = 2.47 acres
 1 sq. kilometer = 100 sq. hectometers = .386 sq. mile

Cubic Measure

1 cu. centimeter = 1000 cu. millimeters = .06 cu. inch
 1 cu. decimeter = 1000 cu. centimeters = 61.02 cu. inches
 1 cu. meter = 1000 cu. decimeters = 35.31 cu. feet

Approximate Conversion Factors

To change	To	Multiply by	To change	To	Multiply by
inches	centimeters	2.540	ounce-inches	newton-meters	.007062
feet	meters	.305	centimeters	inches	.394
yards	meters	.914	meters	feet	3.280
miles	kilometers	1.609	meters	yards	1.094
square inches	square centimeters	6.451	kilometers	miles	.621
square feet	square meters	.093	square centimeters	square inches	.155
square yards	square meters	.836	square meters	square feet	10.764
square miles	square kilometers	2.590	square meters	square yards	1.196
acres	square hectometers	.405	square kilometers	square miles	.386
cubic feet	cubic meters	.028	square hectometers	acres	2.471
cubic yards	cubic meters	.765	cubic meters	cubic feet	35.315
fluid ounces	milliliters	29.573	cubic meters	cubic yards	1.308
pints	liters	.473	milliliters	fluid ounces	.034
quarts	liters	.946	liters	pints	2.113
gallons	liters	3.785	liters	quarts	1.057
ounces	grams	28.349	liters	gallons	.264
pounds	kilograms	.454	grams	ounces	.035
short tons	metric tons	.907	kilograms	pounds	2.205
pound-feet	newton-meters	1.356	metric tons	short tons	1.102
pound-inches	newton-meters	.11296			

Temperature (Exact)

^oF Fahrenheit
temperature

5/9 (after
subtracting 32)

Celsius
temperature

^oC

